

HOUSE SITING PLAN PROPOSED LOT 422

Cancelling part of Lot 1007 on SP298953
Locality of Narangba

- These notes form an integral part of this plan. No part of this plan may be reproduced without these notes being included.
- This preliminary house siting plan (PHSP) is intended as an aid in forming an appreciation of the house design potential of the site. It provides a diagrammatic representation of the current Moreton Bay Regional Council Planning Scheme (V4) Dwelling House Code and Queensland Development Code setback requirements applying to the proposed lot. Additional siting requirements may be dictated by the local authority planning scheme or imposed by conditions of the development application approval relating to the creation of the proposed lot. The details shown on this plan are general in nature and are not a comprehensive compilation of standards or conditions to which this proposed lot may be subject. Prospective buyers and builders should seek advice from the approving authority regarding the specific house siting and building restrictions applying to this proposed lot. In addition, service locations indicated on this plan are preliminary only and may differ from the as constructed product.
- The PHSP is not a statutory disclosure.

Contour Interval – 0.25 metre

- 50.0 — Design Contours
- Retaining Wall (Due to plotting limitations the retaining walls shown are not to scale and are indicative only)
- #### Pad Level
- S Sewer Line/ Manhole
- SW Stormwater Line / Manhole
- W Water Line / Fire Hydrant/ Stop Valve
- (SR) Rising Sewer
- X Water Meter
- Easement Boundary
- Concrete Footpath or Driveway
* Driveways shown are indicative only
- Building Location Envelope
- Built to Boundary Mandatory
- Lower Level (≤ 4.5m Building Height)
- Upper Level (> 4.5m to 7.5m Building Height)
- x-x Garage Limit
- △△ Nominated Garage Location

Meridian: MGA Zone 56 Yes No
Contour Height Datum: AHD

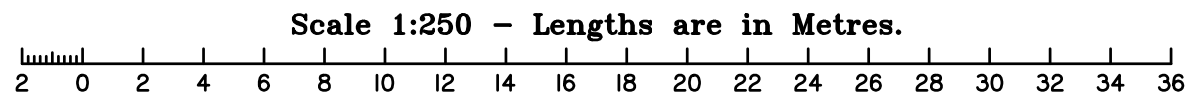
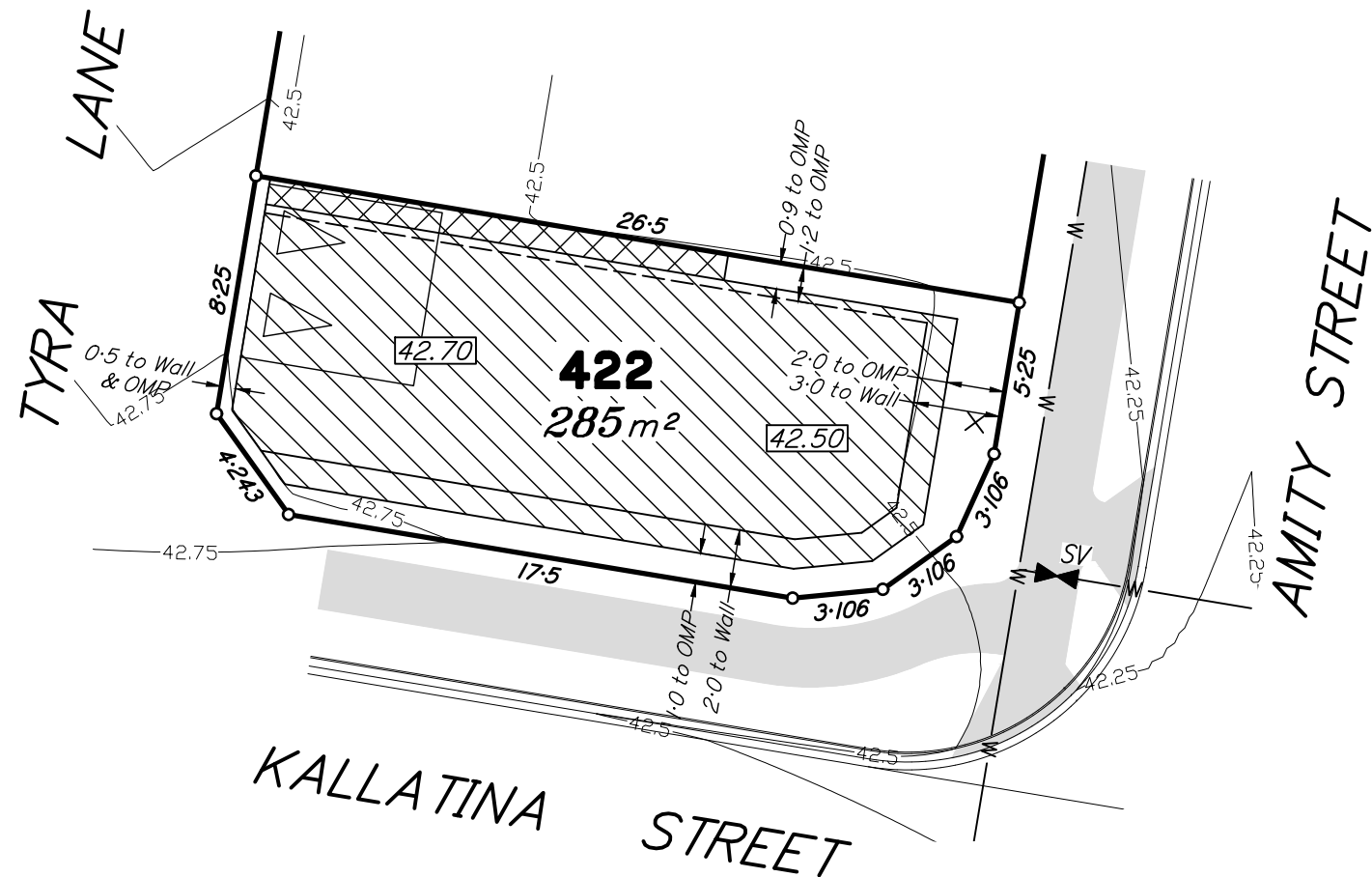
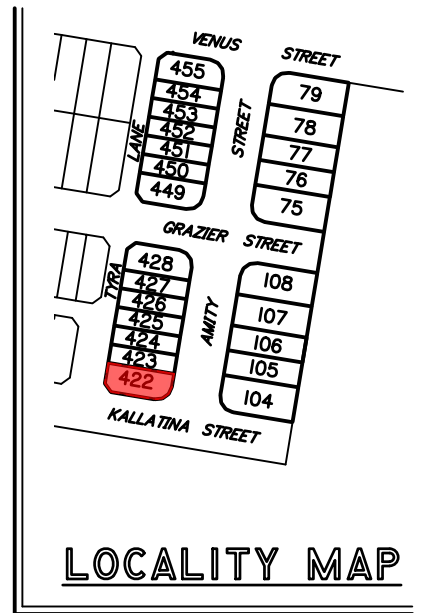
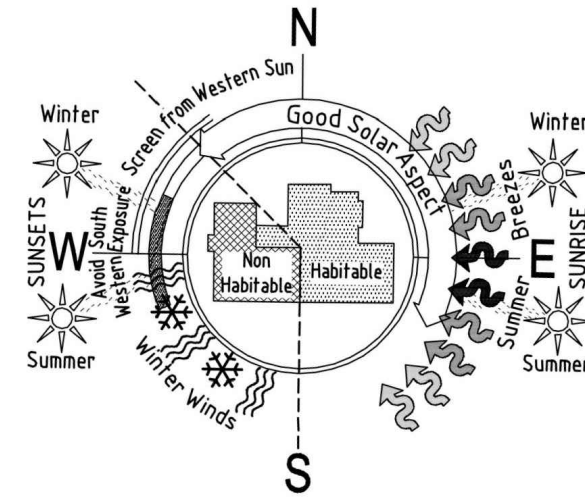

A	ORIGINAL ISSUE	22/04/22	AA	LM
Issue	Details	Date	Drawn	Checked

HOUSE SITING PLAN
POINTCORP NARANGBA PTY LTD
STAGE 4 "AMITY"
CALLAGHAN ROAD, NARANGBA

Dwg No: A3-6488/422	Issue: A
Project: BNE150725	
File: B150725Hs4.dwg	

HOUSE SITING PLAN PROPOSED LOT 423

Cancelling part of Lot 1007 on SP298953
Locality of Narangba

- These notes form an integral part of this plan. No part of this plan may be reproduced without these notes being included.
- This preliminary house siting plan (PHSP) is intended as an aid in forming an appreciation of the house design potential of the site. It provides a diagrammatic representation of the current Moreton Bay Regional Council Planning Scheme (V4) Dwelling House Code and Queensland Development Code setback requirements applying to the proposed lot. Additional siting requirements may be dictated by the local authority planning scheme or imposed by conditions of the development application approval relating to the creation of the proposed lot. The details shown on this plan are general in nature and are not a comprehensive compilation of standards or conditions to which this proposed lot may be subject. Prospective buyers and builders should seek advice from the approving authority regarding the specific house siting and building restrictions applying to this proposed lot. In addition, service locations indicated on this plan are preliminary only and may differ from the as constructed product.
- The PHSP is not a statutory disclosure.

Contour Interval – 0.25 metre

- 50.0 — Design Contours
- Retaining Wall (Due to plotting limitations the retaining walls shown are not to scale and are indicative only)
- #### Pad Level
- S — Sewer Line/ Manhole
- SW — Stormwater Line / Manhole
- w — Water Line / Fire Hydrant/ Stop Valve
- (SR) — Rising Sewer
- X Water Meter
- — Easement Boundary
- Concrete Footpath or Driveway
* Driveways shown are indicative only
- Building Location Envelope
- Built to Boundary Mandatory
- Lower Level (≤ 4.5m Building Height)
- Upper Level (> 4.5m to 7.5m Building Height)
- x-x Garage Limit
- △△ Nominated Garage Location

Meridian: MGA Zone 56 Yes No
Contour Height Datum: AHD

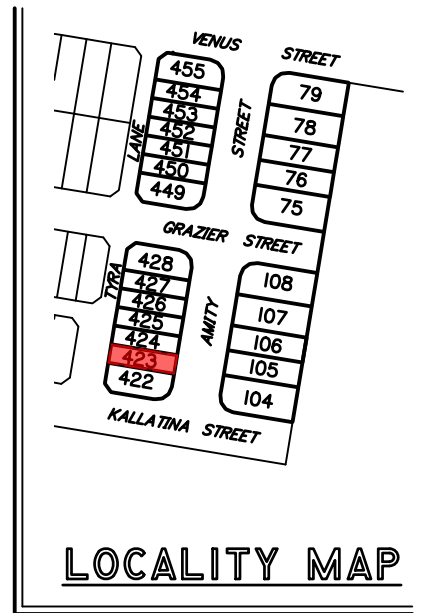
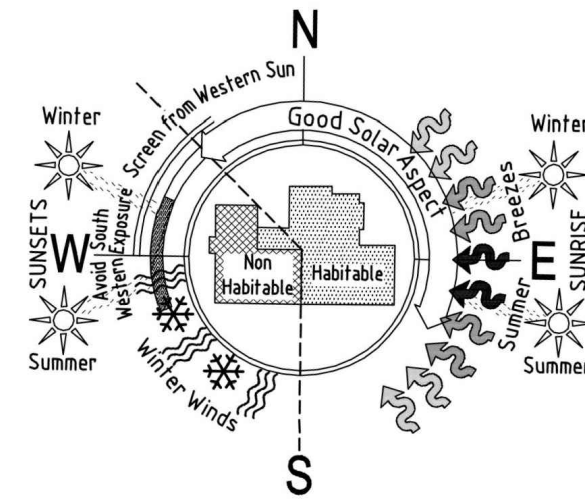

LOCALITY MAP

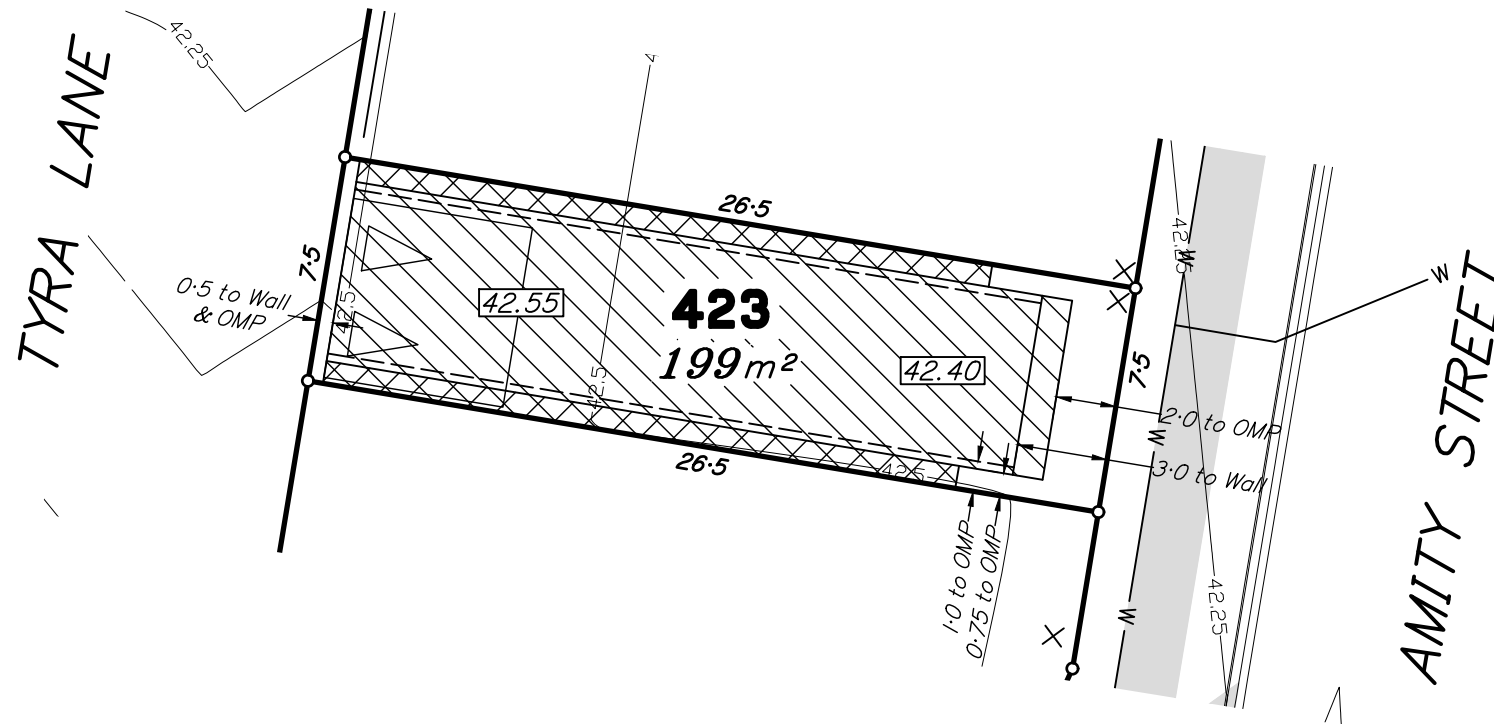

Scale 1:250 – Lengths are in Metres.

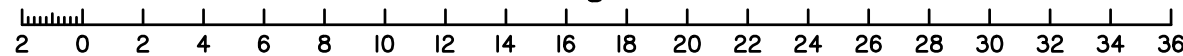

dts urban planning, surveying & development
Brisbane
PO Box 3128, West End QLD 4101
Ph: 07 3118 0600
brisbane@dtsqld.com.au

Mackay
PO Box 11711, Mackay Caneland QLD 4740
Ph: 1300 278 783
mackay@dtsqld.com.au

A	ORIGINAL ISSUE	26/04/22	AA	LM
Issue	Details	Date	Drawn	Checked

HOUSE SITING PLAN
POINTCORP NARANGBA PTY LTD
STAGE 4 "AMITY"
CALLAGHAN ROAD, NARANGBA

Dwg No: A3-6488/423	Issue: A
Project: BNE150725	
File: B150725Hs4.dwg	

HOUSE SITING PLAN PROPOSED LOT 424

Cancelling part of Lot 1007 on SP298953
Locality of Narangba

- These notes form an integral part of this plan. No part of this plan may be reproduced without these notes being included.
- This preliminary house siting plan (PHSP) is intended as an aid in forming an appreciation of the house design potential of the site. It provides a diagrammatic representation of the current Moreton Bay Regional Council Planning Scheme (V4) Dwelling House Code and Queensland Development Code setback requirements applying to the proposed lot. Additional siting requirements may be dictated by the local authority planning scheme or imposed by conditions of the development application approval relating to the creation of the proposed lot. The details shown on this plan are general in nature and are not a comprehensive compilation of standards or conditions to which this proposed lot may be subject. Prospective buyers and builders should seek advice from the approving authority regarding the specific house siting and building restrictions applying to this proposed lot. In addition, service locations indicated on this plan are preliminary only and may differ from the as constructed product.
- The PHSP is not a statutory disclosure.

Contour Interval – 0.25 metre

- 50.0 — Design Contours
- Retaining Wall (Due to plotting limitations the retaining walls shown are not to scale and are indicative only)
- #### Pad Level
- S — Sewer Line/ Manhole
- SW — Stormwater Line / Manhole
- W — Water Line / Fire Hydrant/ Stop Valve
- (SR) — Rising Sewer
- X Water Meter
- Easement Boundary
- Concrete Footpath or Driveway
* Driveways shown are indicative only
- Building Location Envelope
- Built to Boundary Mandatory
- Lower Level (≤ 4.5m Building Height)
- Upper Level (> 4.5m to 7.5m Building Height)
- x-x Garage Limit
- △△ Nominated Garage Location

Meridian: MGA Zone 56 Yes No
Contour Height Datum: AHD

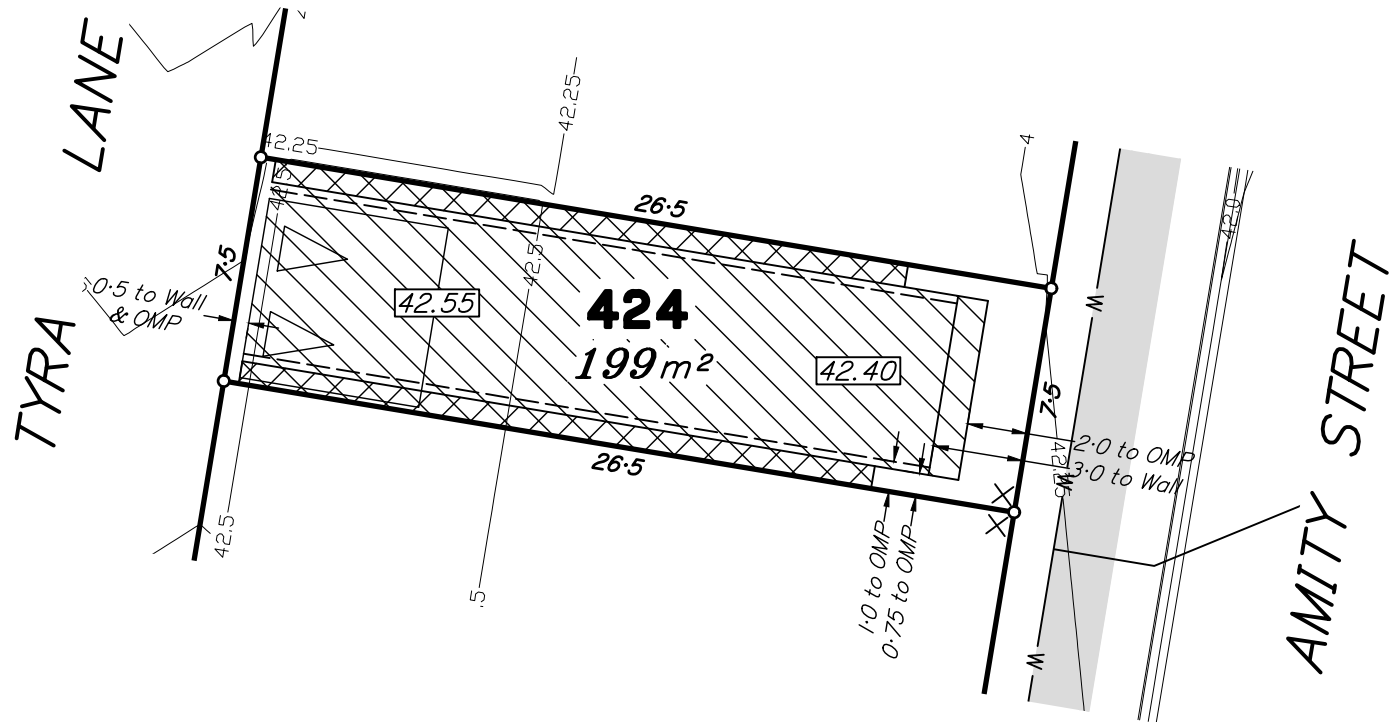
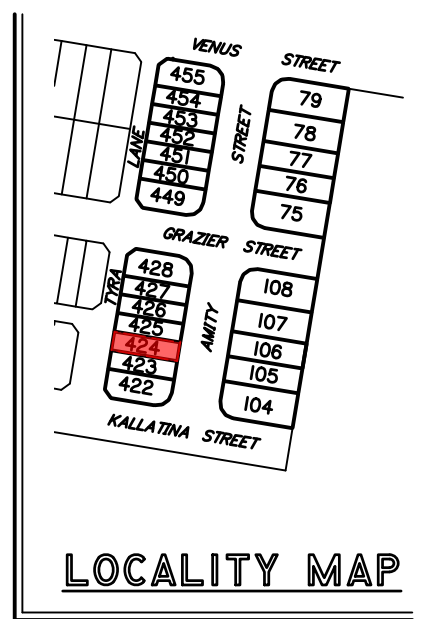
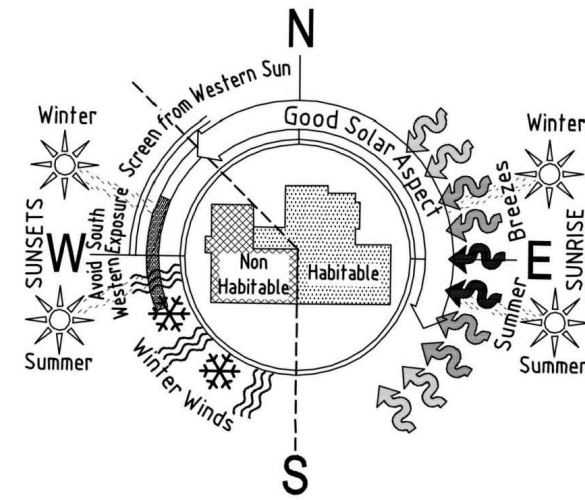

Scale 1:250 – Lengths are in Metres.
0 2 4 6 8 10 12 14 16 18 20 22 24 26 28 30 32 34 36

A	ORIGINAL ISSUE	22/04/22	AA	LM
Issue	Details	Date	Drawn	Checked

HOUSE SITING PLAN
POINTCORP NARANGBA PTY LTD
STAGE 4 "AMITY"
CALLAGHAN ROAD, NARANGBA

Dwg No: A3-6488/424	Issue: A
Project: BNE150725	
File: B150725Hs4.dwg	

HOUSE SITING PLAN PROPOSED LOT 425

Cancelling part of Lot 1007 on SP298953
Locality of Narangba

- These notes form an integral part of this plan. No part of this plan may be reproduced without these notes being included.
- This preliminary house siting plan (PHSP) is intended as an aid in forming an appreciation of the house design potential of the site. It provides a diagrammatic representation of the current Moreton Bay Regional Council Planning Scheme (V4) Dwelling House Code and Queensland Development Code setback requirements applying to the proposed lot. Additional siting requirements may be dictated by the local authority planning scheme or imposed by conditions of the development application approval relating to the creation of the proposed lot. The details shown on this plan are general in nature and are not a comprehensive compilation of standards or conditions to which this proposed lot may be subject. Prospective buyers and builders should seek advice from the approving authority regarding the specific house siting and building restrictions applying to this proposed lot. In addition, service locations indicated on this plan are preliminary only and may differ from the as constructed product.
- The PHSP is not a statutory disclosure.

Contour Interval – 0.25 metre

- 50.0 — Design Contours
- Retaining Wall (Due to plotting limitations the retaining walls shown are not to scale and are indicative only)
- #### Pad Level
- S — Sewer Line/ Manhole
- SW — Stormwater Line / Manhole
- w — Water Line / Fire Hydrant/ Stop Valve
- (SR) — Rising Sewer
- X Water Meter
- — Easement Boundary
- Concrete Footpath or Driveway
* Driveways shown are indicative only
- Building Location Envelope
- Built to Boundary Mandatory
- Lower Level (≤ 4.5m Building Height)
- Upper Level (> 4.5m to 7.5m Building Height)
- x-x Garage Limit
- △△ Nominated Garage Location

Meridian: MGA Zone 56 Yes No
Contour Height Datum: AHD

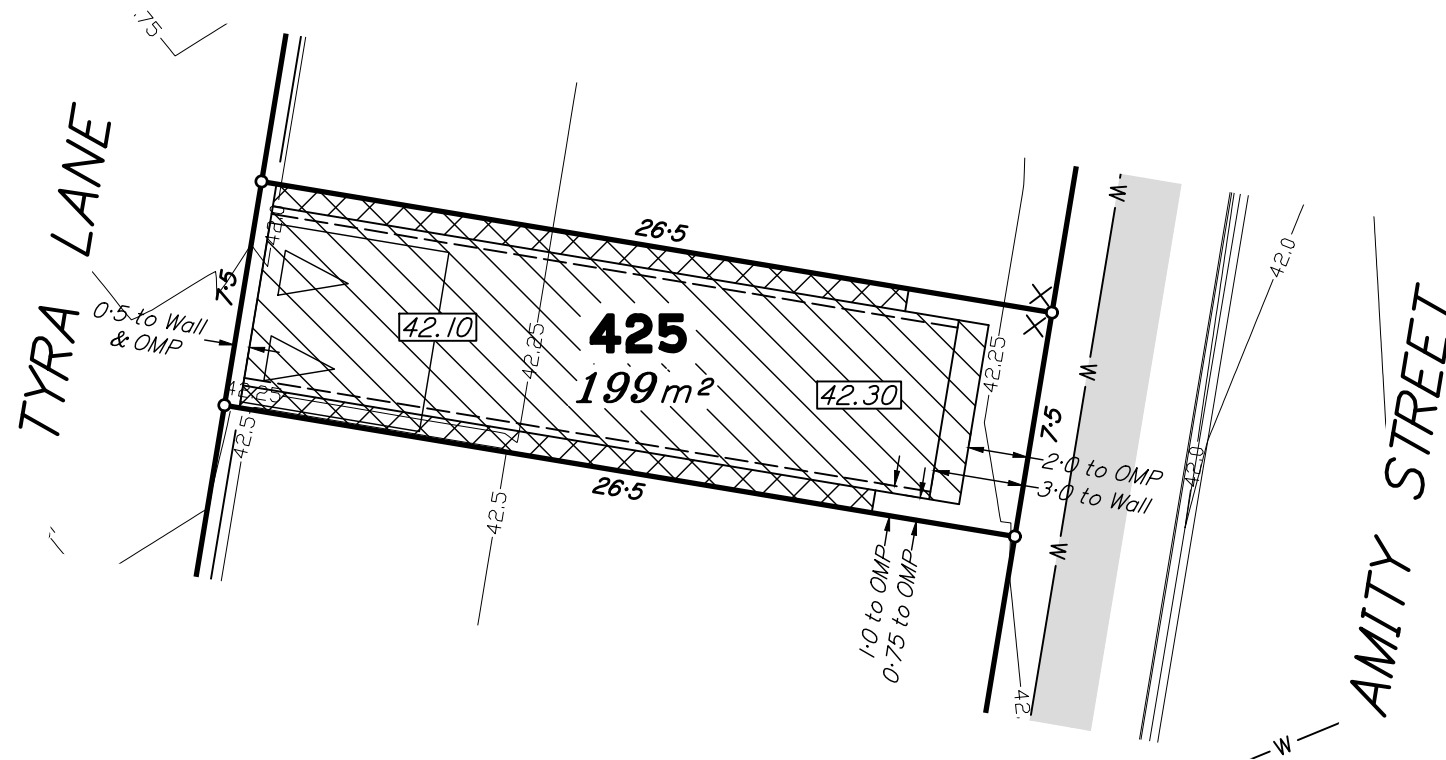
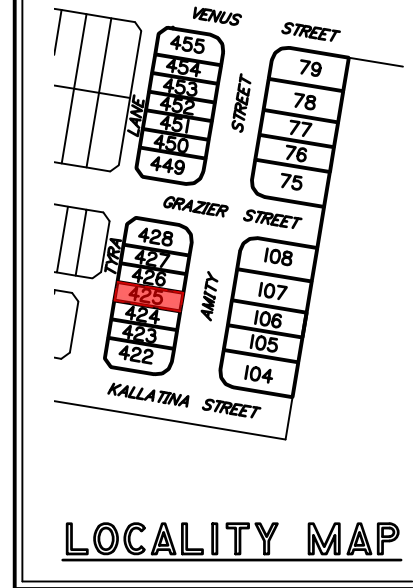
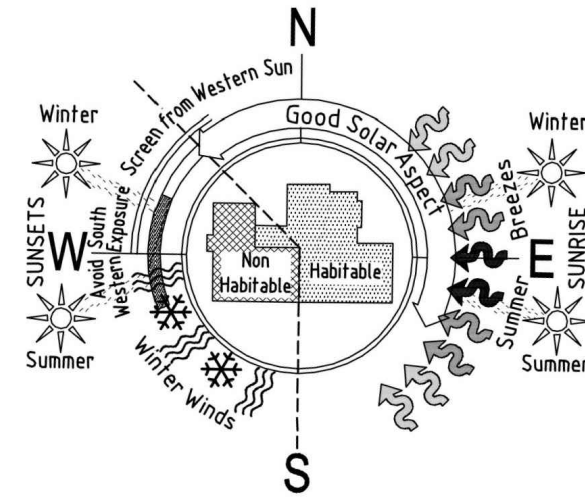

Scale 1:250 – Lengths are in Metres.

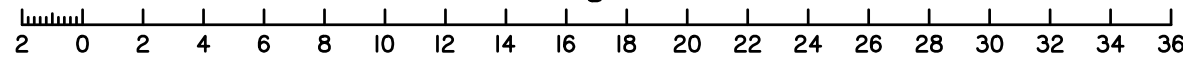

dts urban planning, surveying & development
Brisbane
PO Box 3128, West End QLD 4101
Ph: 07 3118 0600
brisbane@dtsqld.com.au

Mackay
PO Box 11711, Mackay Caneland QLD 4740
Ph: 1300 278 783
mackay@dtsqld.com.au

A	ORIGINAL ISSUE	26/04/22	AA	LM
Issue	Details	Date	Drawn	Checked

HOUSE SITING PLAN
POINTCORP NARANGBA PTY LTD
STAGE 4 "AMITY"
CALLAGHAN ROAD, NARANGBA

Dwg No: A3-6488/425	Issue: A
Project: BNE150725	
File: B150725Hs4.dwg	

HOUSE SITING PLAN PROPOSED LOT 426

Cancelling part of Lot 1007 on SP298953
Locality of Narangba

- These notes form an integral part of this plan. No part of this plan may be reproduced without these notes being included.
- This preliminary house siting plan (PHSP) is intended as an aid in forming an appreciation of the house design potential of the site. It provides a diagrammatic representation of the current Moreton Bay Regional Council Planning Scheme (V4) Dwelling House Code and Queensland Development Code setback requirements applying to the proposed lot. Additional siting requirements may be dictated by the local authority planning scheme or imposed by conditions of the development application approval relating to the creation of the proposed lot. The details shown on this plan are general in nature and are not a comprehensive compilation of standards or conditions to which this proposed lot may be subject. Prospective buyers and builders should seek advice from the approving authority regarding the specific house siting and building restrictions applying to this proposed lot. In addition, service locations indicated on this plan are preliminary only and may differ from the as constructed product.
- The PHSP is not a statutory disclosure.

Contour Interval – 0.25 metre

- 50.0 — Design Contours
- Retaining Wall (Due to plotting limitations the retaining walls shown are not to scale and are indicative only)
- #### Pad Level
- S — Sewer Line/ Manhole
- SW — Stormwater Line / Manhole
- w — Water Line / Fire Hydrant/ Stop Valve
- (SR) — Rising Sewer
- X Water Meter
- Easement Boundary
- Concrete Footpath or Driveway
* Driveways shown are indicative only
- Building Location Envelope
- Built to Boundary Mandatory
- Lower Level (≤ 4.5m Building Height)
- Upper Level (> 4.5m to 7.5m Building Height)
- x-x Garage Limit
- △△ Nominated Garage Location

Meridian: MGA Zone 56 Yes No
Contour Height Datum: AHD

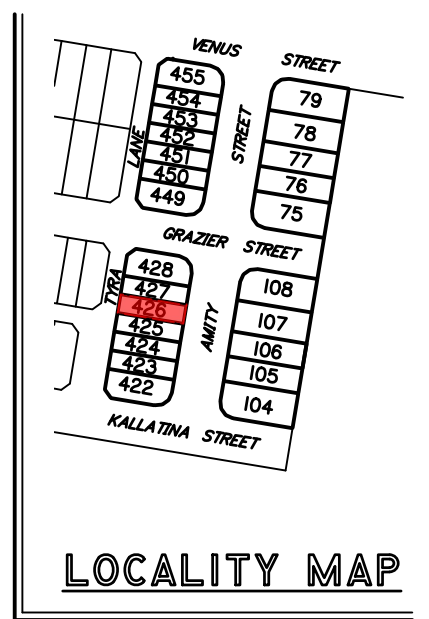
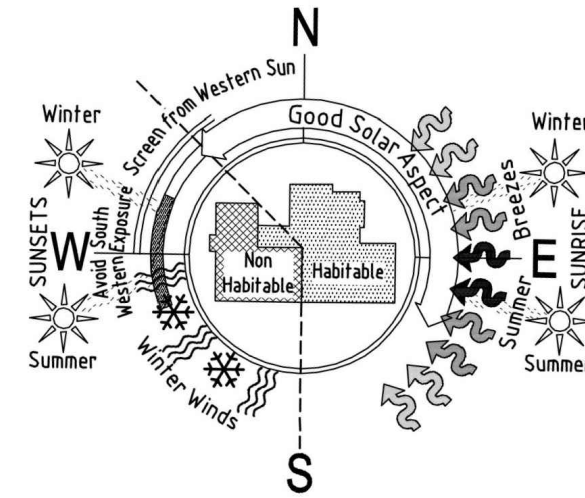

LOCALITY MAP

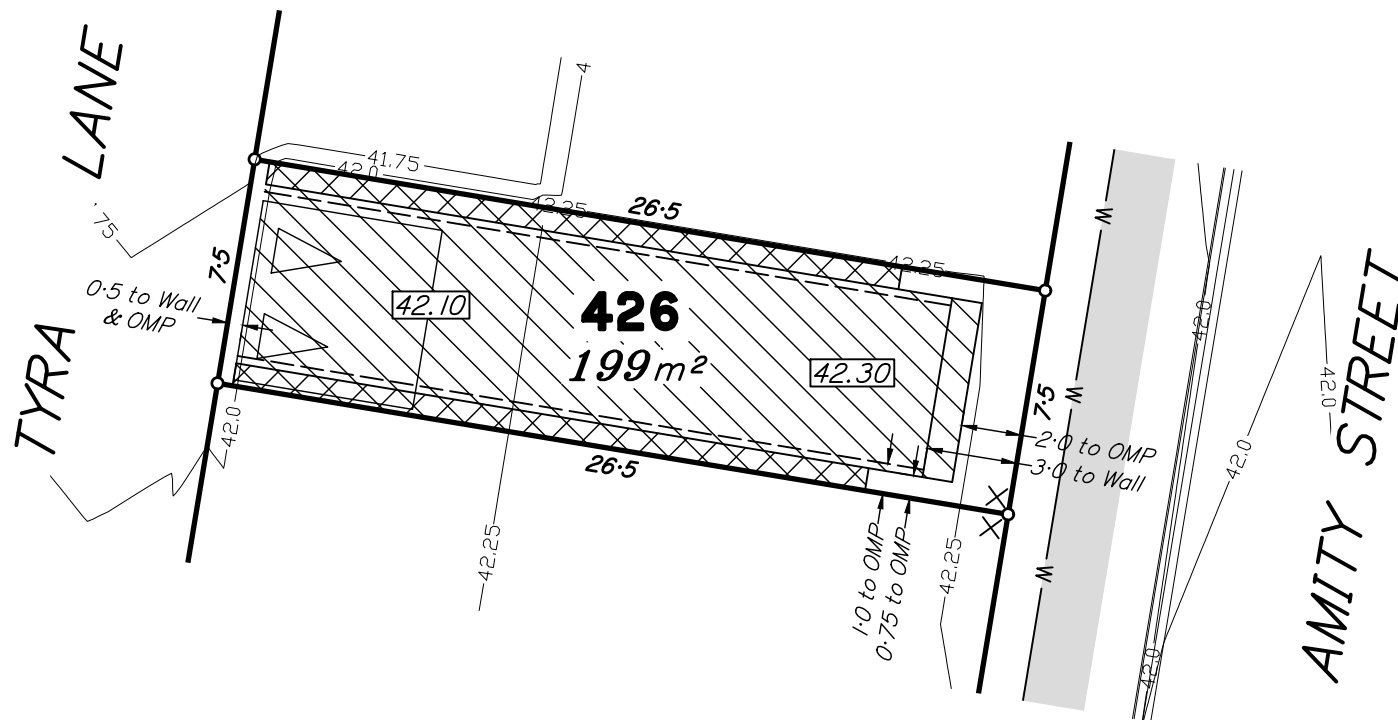

Scale 1:250 – Lengths are in Metres.

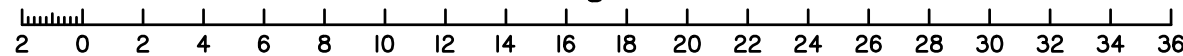

dts urban planning, surveying & development
Brisbane
PO Box 3128, West End QLD 4101
Ph: 07 3118 0600
brisbane@dtsqld.com.au

Mackay
PO Box 11711, Mackay Caneland QLD 4740
Ph: 1300 278 783
mackay@dtsqld.com.au

A	ORIGINAL ISSUE	22/04/22	AA	LM
Issue	Details	Date	Drawn	Checked

HOUSE SITING PLAN
POINTCORP NARANGBA PTY LTD
STAGE 4 "AMITY"
CALLAGHAN ROAD, NARANGBA

Dwg No: A3-6488/426	Issue: A
Project: BNE150725	
File: B150725Hs4.dwg	

HOUSE SITING PLAN PROPOSED LOT 427

Cancelling part of Lot 1007 on SP298953
Locality of Narangba

- These notes form an integral part of this plan. No part of this plan may be reproduced without these notes being included.
- This preliminary house siting plan (PHSP) is intended as an aid in forming an appreciation of the house design potential of the site. It provides a diagrammatic representation of the current Moreton Bay Regional Council Planning Scheme (V4) Dwelling House Code and Queensland Development Code setback requirements applying to the proposed lot. Additional siting requirements may be dictated by the local authority planning scheme or imposed by conditions of the development application approval relating to the creation of the proposed lot. The details shown on this plan are general in nature and are not a comprehensive compilation of standards or conditions to which this proposed lot may be subject. Prospective buyers and builders should seek advice from the approving authority regarding the specific house siting and building restrictions applying to this proposed lot. In addition, service locations indicated on this plan are preliminary only and may differ from the as constructed product.
- The PHSP is not a statutory disclosure.

Contour Interval – 0.25 metre

- 50.0 — Design Contours
- Retaining Wall (Due to plotting limitations the retaining walls shown are not to scale and are indicative only)
- #### Pad Level
- S — Sewer Line / Manhole
- SW — Stormwater Line / Manhole
- W — Water Line / Fire Hydrant / Stop Valve
- (SR) — Rising Sewer
- X Water Meter
- — Easement Boundary
- Concrete Footpath or Driveway
* Driveways shown are indicative only
- Building Location Envelope
- Built to Boundary Mandatory
- Lower Level (≤ 4.5m Building Height)
- Upper Level (> 4.5m to 7.5m Building Height)
- x-x Garage Limit
- △△ Nominated Garage Location

Meridian: MGA Zone 56 Yes No
Contour Height Datum: AHD

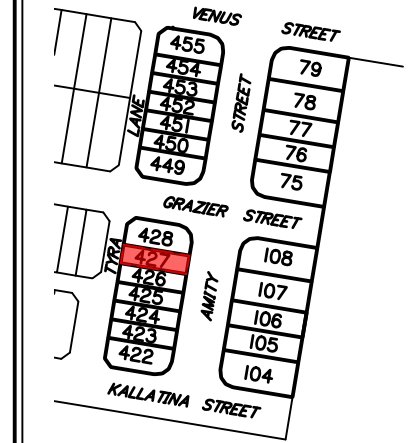
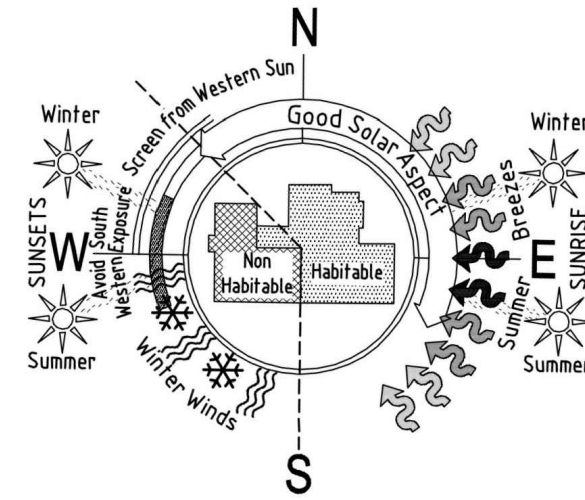

LOCALITY MAP

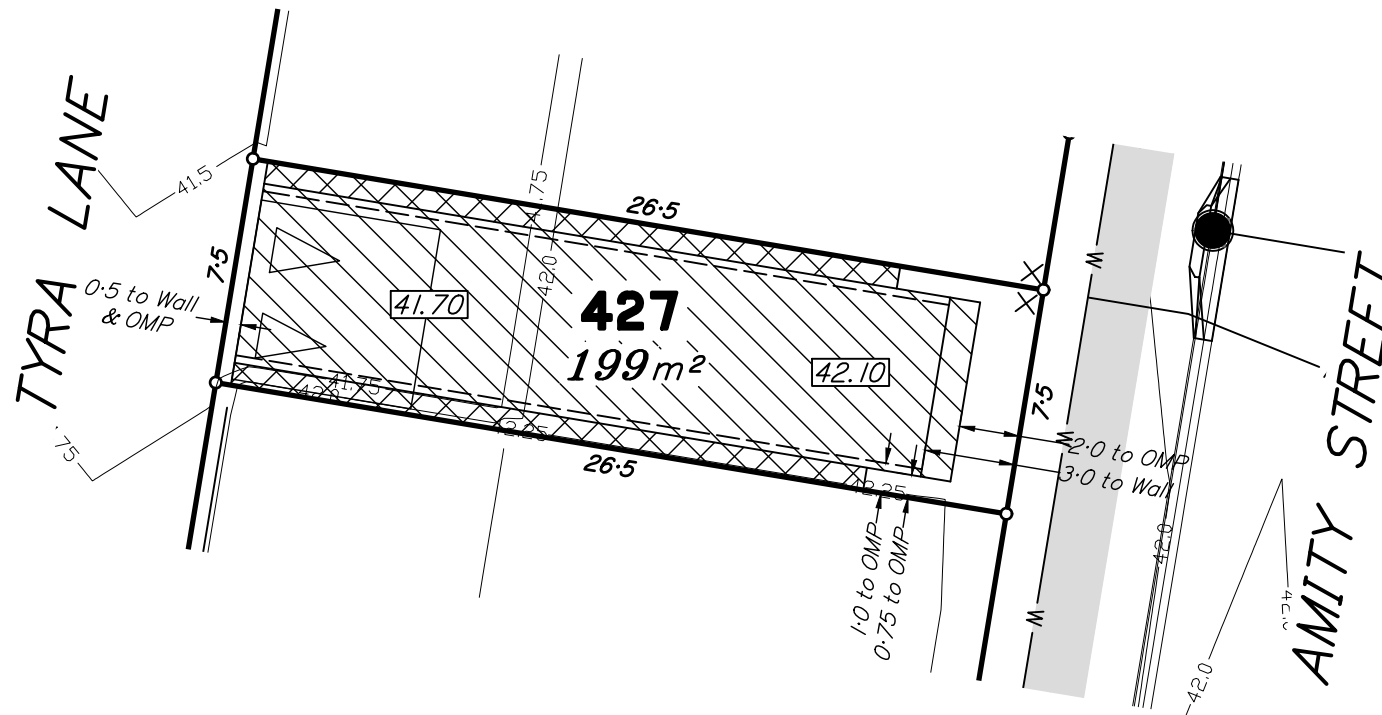

Scale 1:250 – Lengths are in Metres.

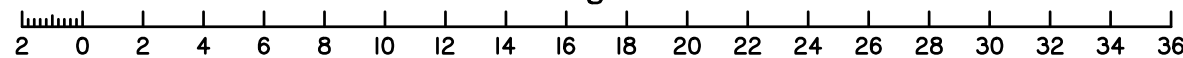

dts urban planning, surveying & development
Brisbane
PO Box 3128, West End QLD 4101
Ph: 07 3118 0600
brisbane@dtsqld.com.au

Mackay
PO Box 11711, Mackay Caneland QLD 4740
Ph: 1300 278 783
mackay@dtsqld.com.au

A	ORIGINAL ISSUE	26/04/22	AA	LM
Issue	Details	Date	Drawn	Checked

HOUSE SITING PLAN
POINTCORP NARANGBA PTY LTD
STAGE 4 "AMITY"
CALLAGHAN ROAD, NARANGBA

Dwg No: A3-6488/427	Issue: A
Project: BNE150725	
File: B150725Hs4.dwg	

HOUSE SITING PLAN PROPOSED LOT 428

Cancelling part of Lot 1007 on SP298953
Locality of Narangba

- These notes form an integral part of this plan. No part of this plan may be reproduced without these notes being included.
- This preliminary house siting plan (PHSP) is intended as an aid in forming an appreciation of the house design potential of the site. It provides a diagrammatic representation of the current Moreton Bay Regional Council Planning Scheme (V4) Dwelling House Code and Queensland Development Code setback requirements applying to the proposed lot. Additional siting requirements may be dictated by the local authority planning scheme or imposed by conditions of the development application approval relating to the creation of the proposed lot. The details shown on this plan are general in nature and are not a comprehensive compilation of standards or conditions to which this proposed lot may be subject. Prospective buyers and builders should seek advice from the approving authority regarding the specific house siting and building restrictions applying to this proposed lot. In addition, service locations indicated on this plan are preliminary only and may differ from the as constructed product.
- The PHSP is not a statutory disclosure.

Contour Interval – 0.25 metre

- 50.0 — Design Contours
- Retaining Wall (Due to plotting limitations the retaining walls shown are not to scale and are indicative only)
- #### Pad Level
- S — Sewer Line / Manhole
- SW — Stormwater Line / Manhole
- W — Water Line / Fire Hydrant / Stop Valve
- (SR) — Rising Sewer
- X Water Meter
- Easement Boundary
- Concrete Footpath or Driveway
* Driveways shown are indicative only
- Building Location Envelope
- Built to Boundary Mandatory
- Lower Level (≤ 4.5m Building Height)
- Upper Level (> 4.5m to 7.5m Building Height)
- x-x Garage Limit
- △△ Nominated Garage Location

Meridian: MGA Zone 56 Yes No
Contour Height Datum: AHD

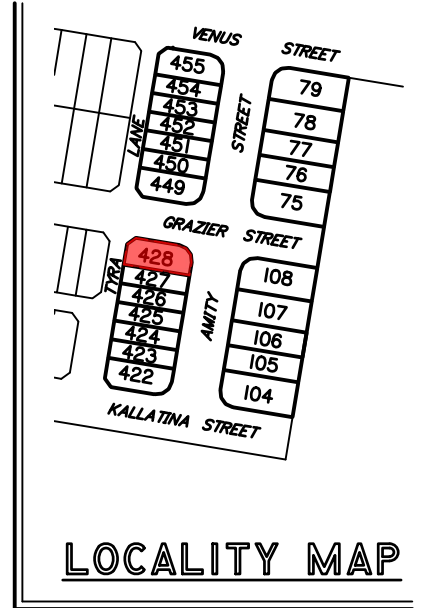
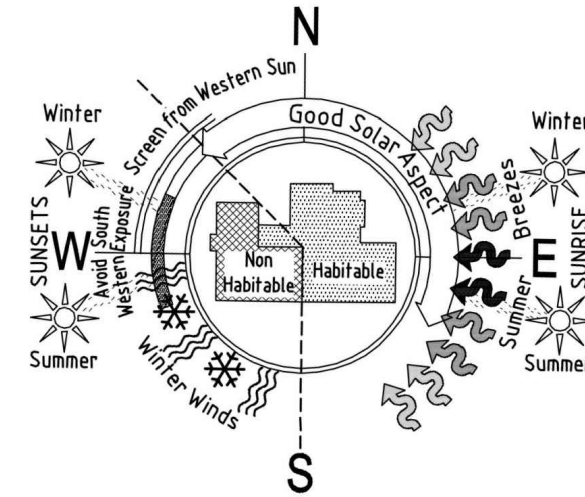

LOCALITY MAP

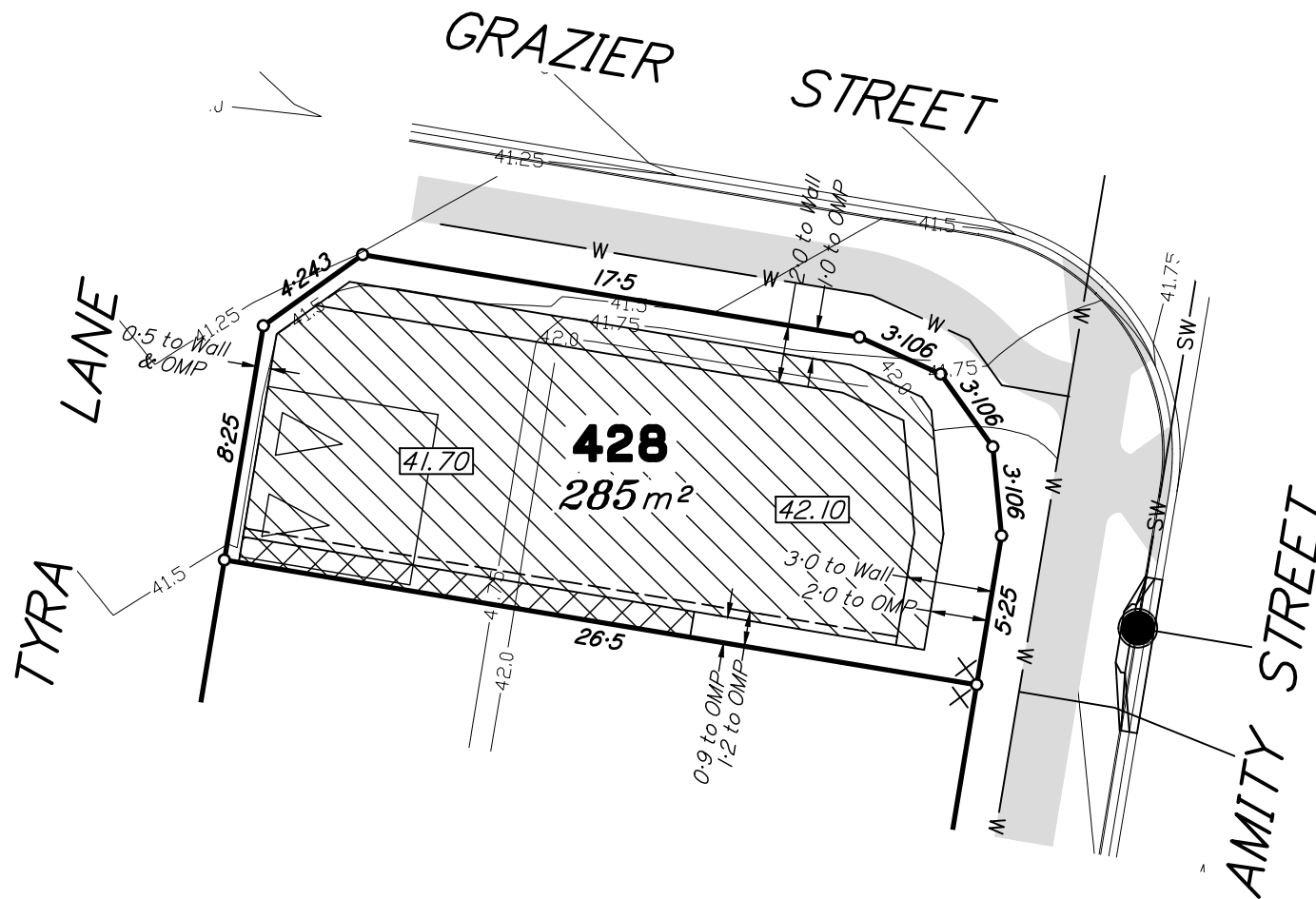

Scale 1:250 – Lengths are in Metres.

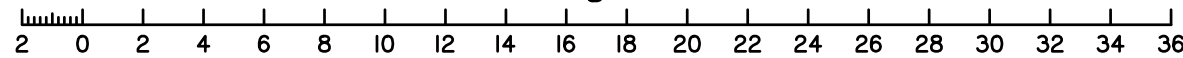

dts urban planning, surveying & development
Brisbane
PO Box 3128, West End QLD 4101
Ph: 07 3118 0600
brisbane@dtsqld.com.au

Mackay
PO Box 11711, Mackay Caneland QLD 4740
Ph: 1300 278 783
mackay@dtsqld.com.au

A	ORIGINAL ISSUE	22/04/22	AA	LM
Issue	Details	Date	Drawn	Checked

HOUSE SITING PLAN
POINTCORP NARANGBA PTY LTD
STAGE 4 "AMITY"
CALLAGHAN ROAD, NARANGBA

Dwg No: A3-6488/428	Issue: A
Project: BNE150725	
File: B150725Hs4.dwg	

HOUSE SITING PLAN PROPOSED LOT 449

Cancelling part of Lot 1007 on SP298953
Locality of Narangba

- These notes form an integral part of this plan. No part of this plan may be reproduced without these notes being included.
- This preliminary house siting plan (PHSP) is intended as an aid in forming an appreciation of the house design potential of the site. It provides a diagrammatic representation of the current Moreton Bay Regional Council Planning Scheme (V4) Dwelling House Code and Queensland Development Code setback requirements applying to the proposed lot. Additional siting requirements may be dictated by the local authority planning scheme or imposed by conditions of the development application approval relating to the creation of the proposed lot. The details shown on this plan are general in nature and are not a comprehensive compilation of standards or conditions to which this proposed lot may be subject. Prospective buyers and builders should seek advice from the approving authority regarding the specific house siting and building restrictions applying to this proposed lot. In addition, service locations indicated on this plan are preliminary only and may differ from the as constructed product.
- The PHSP is not a statutory disclosure.

Contour Interval – 0.25 metre

- 50.0 — Design Contours
- Retaining Wall (Due to plotting limitations the retaining walls shown are not to scale and are indicative only)
- ### Pad Level
- S Sewer Line/ Manhole
- SW Stormwater Line / Manhole
- W Water Line / Fire Hydrant/ Stop Valve
- (SR) Rising Sewer
- X Water Meter
- Easement Boundary
- Concrete Footpath or Driveway
* Driveways shown are indicative only
- Building Location Envelope
- Built to Boundary Mandatory
- Lower Level (≤ 4.5m Building Height)
- Upper Level (> 4.5m to 7.5m Building Height)
- x-x Garage Limit
- △△ Nominated Garage Location

Meridian: MGA Zone 56 Yes No
Contour Height Datum: AHD

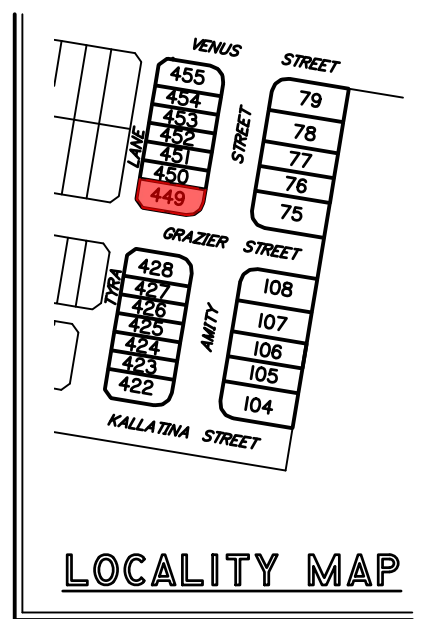
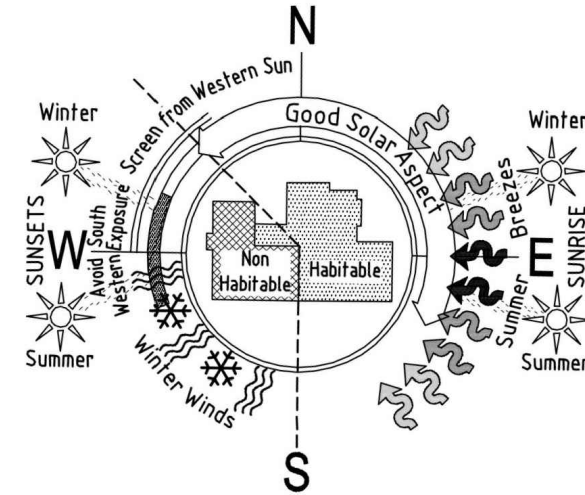

LOCALITY MAP

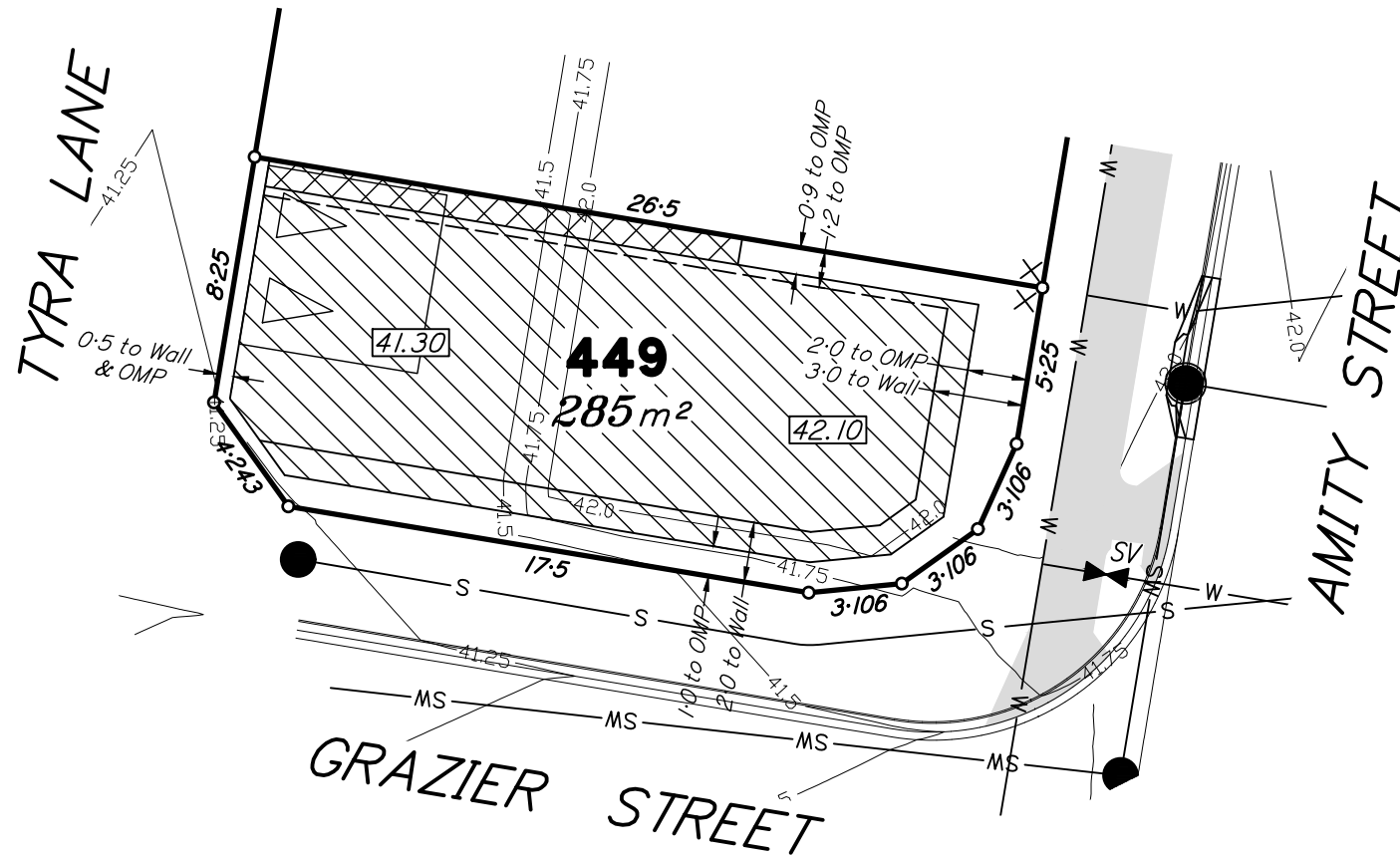

Scale 1:250 – Lengths are in Metres.

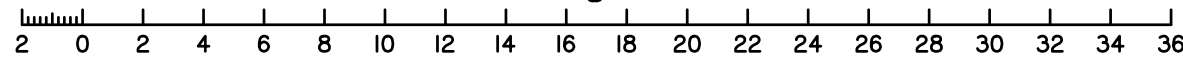

dts urban planning, surveying & development
Brisbane
PO Box 3128, West End QLD 4101
Ph: 07 3118 0600
brisbane@dtsqld.com.au

Mackay
PO Box 11711, Mackay Caneland QLD 4740
Ph: 1300 278 783
mackay@dtsqld.com.au

A	ORIGINAL ISSUE	26/04/22	AA	LM
Issue	Details	Date	Drawn	Checked

HOUSE SITING PLAN
POINTCORP NARANGBA PTY LTD
STAGE 4 "AMITY"
CALLAGHAN ROAD, NARANGBA

Dwg No: A3-6488/449	Issue: A
Project: BNE150725	
File: B150725Hs4.dwg	

HOUSE SITING PLAN PROPOSED LOT 450

Cancelling part of Lot 1007 on SP298953
Locality of Narangba

- These notes form an integral part of this plan. No part of this plan may be reproduced without these notes being included.
- This preliminary house siting plan (PHSP) is intended as an aid in forming an appreciation of the house design potential of the site. It provides a diagrammatic representation of the current Moreton Bay Regional Council Planning Scheme (V4) Dwelling House Code and Queensland Development Code setback requirements applying to the proposed lot. Additional siting requirements may be dictated by the local authority planning scheme or imposed by conditions of the development application approval relating to the creation of the proposed lot. The details shown on this plan are general in nature and are not a comprehensive compilation of standards or conditions to which this proposed lot may be subject. Prospective buyers and builders should seek advice from the approving authority regarding the specific house siting and building restrictions applying to this proposed lot. In addition, service locations indicated on this plan are preliminary only and may differ from the as constructed product.
- The PHSP is not a statutory disclosure.

Contour Interval – 0.25 metre

- 50.0 — Design Contours
- Retaining Wall (Due to plotting limitations the retaining walls shown are not to scale and are indicative only)
- #### Pad Level
- S — Sewer Line/ Manhole
- SW — Stormwater Line / Manhole
- W — Water Line / Fire Hydrant/ Stop Valve
- (SR) — Rising Sewer
- X Water Meter
- Easement Boundary
- Concrete Footpath or Driveway
* Driveways shown are indicative only
- Building Location Envelope
- Built to Boundary Mandatory
- Lower Level (≤ 4.5m Building Height)
- Upper Level (> 4.5m to 7.5m Building Height)
- x-x Garage Limit
- △△ Nominated Garage Location

Meridian: MGA Zone 56 Yes No
Contour Height Datum: AHD

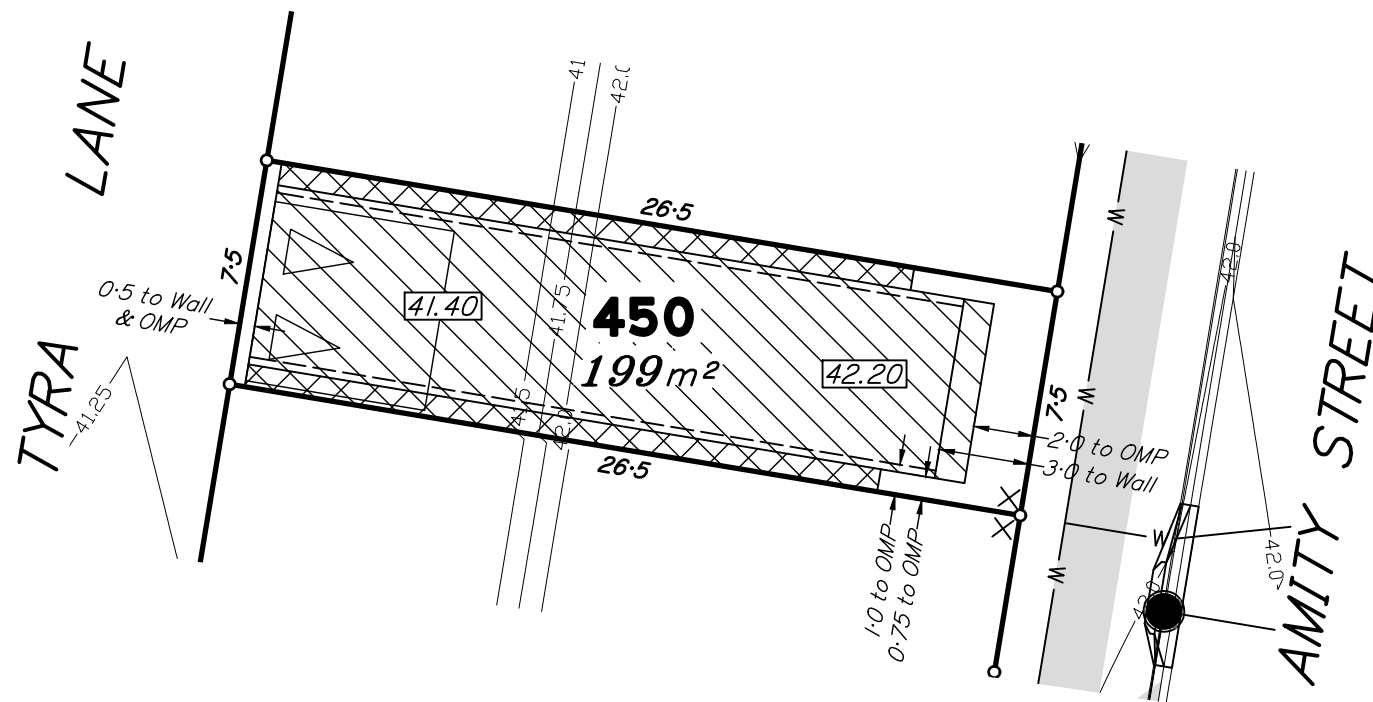
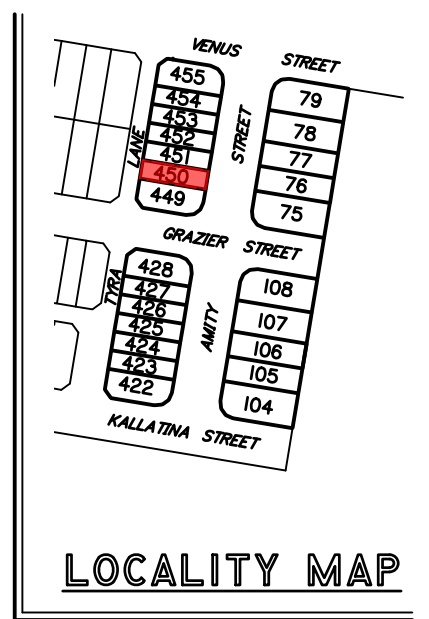
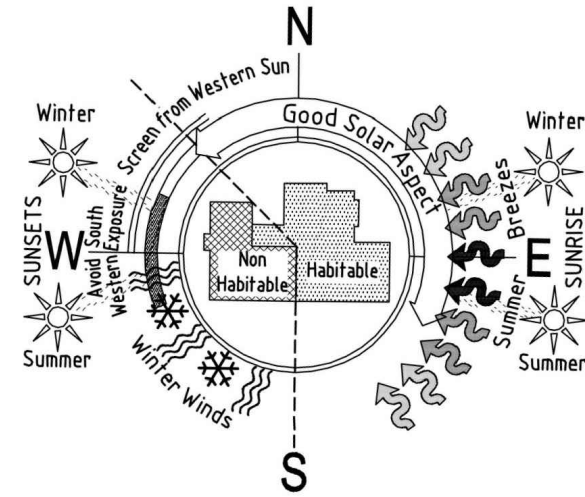

Scale 1:250 – Lengths are in Metres.

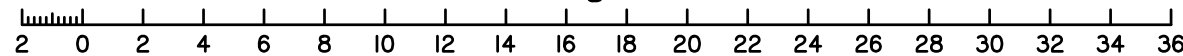

dts urban planning, surveying & development
Brisbane
PO Box 3128, West End QLD 4101
Ph: 07 3118 0600
brisbane@dtsqld.com.au

Mackay
PO Box 11711, Mackay Caneland QLD 4740
Ph: 1300 278 783
mackay@dtsqld.com.au

A	ORIGINAL ISSUE	22/04/22	AA	LM
Issue	Details	Date	Drawn	Checked

HOUSE SITING PLAN
POINTCORP NARANGBA PTY LTD
STAGE 4 "AMITY"
CALLAGHAN ROAD, NARANGBA

Dwg No: A3-6488/450	Issue: A
Project: BNE150725	
File: B150725Hs4.dwg	

HOUSE SITING PLAN PROPOSED LOT 451

Cancelling part of Lot 1007 on SP298953
Locality of Narangba

- These notes form an integral part of this plan. No part of this plan may be reproduced without these notes being included.
- This preliminary house siting plan (PHSP) is intended as an aid in forming an appreciation of the house design potential of the site. It provides a diagrammatic representation of the current Moreton Bay Regional Council Planning Scheme (V4) Dwelling House Code and Queensland Development Code setback requirements applying to the proposed lot. Additional siting requirements may be dictated by the local authority planning scheme or imposed by conditions of the development application approval relating to the creation of the proposed lot. The details shown on this plan are general in nature and are not a comprehensive compilation of standards or conditions to which this proposed lot may be subject. Prospective buyers and builders should seek advice from the approving authority regarding the specific house siting and building restrictions applying to this proposed lot. In addition, service locations indicated on this plan are preliminary only and may differ from the as constructed product.
- The PHSP is not a statutory disclosure.

Contour Interval – 0.25 metre

- 50.0 — Design Contours
- Retaining Wall (Due to plotting limitations the retaining walls shown are not to scale and are indicative only)
- #### Pad Level
- S — Sewer Line/ Manhole
- SW — Stormwater Line / Manhole
- w — Water Line / Fire Hydrant/ Stop Valve
- (SR) — Rising Sewer
- X Water Meter
- Easement Boundary
- Concrete Footpath or Driveway
* Driveways shown are indicative only
- Building Location Envelope
- Built to Boundary Mandatory
- Lower Level (≤ 4.5m Building Height)
- Upper Level (> 4.5m to 7.5m Building Height)
- x-x Garage Limit
- △△ Nominated Garage Location

Meridian: MGA Zone 56 Yes No
Contour Height Datum: AHD

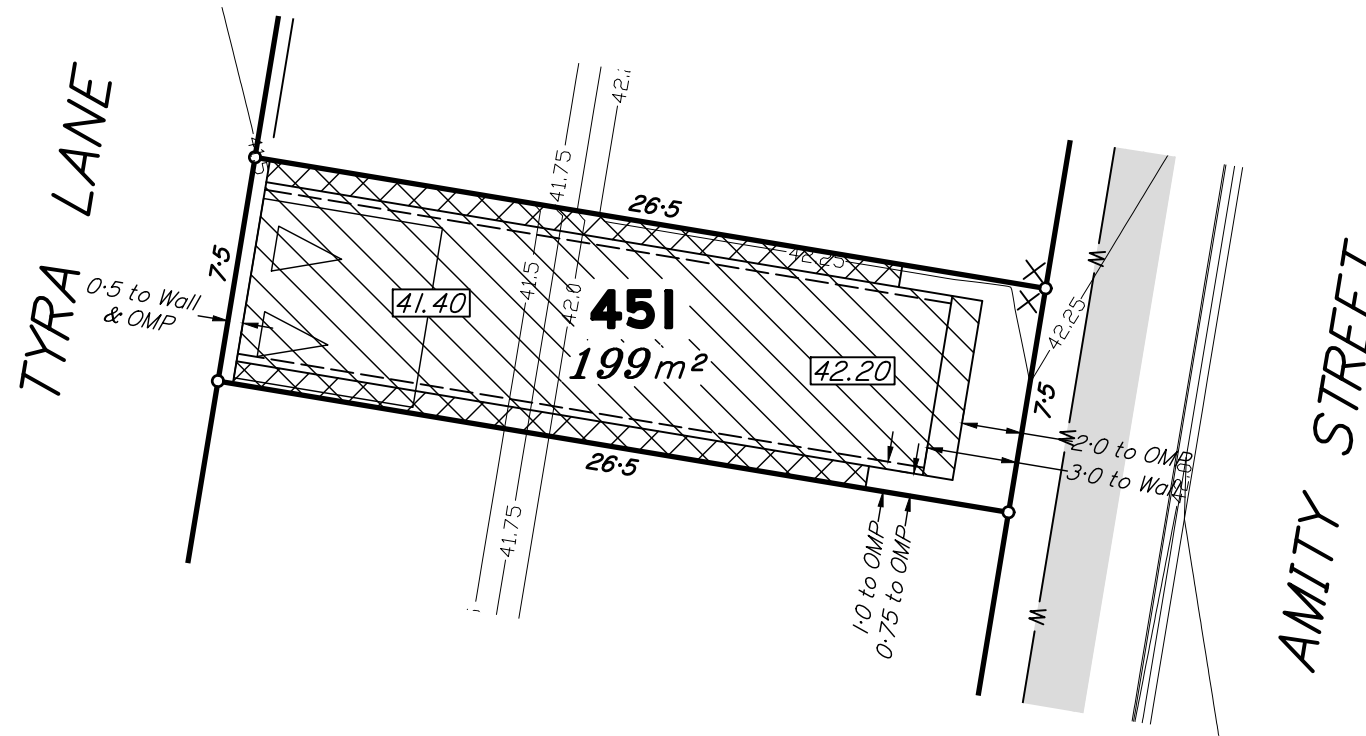
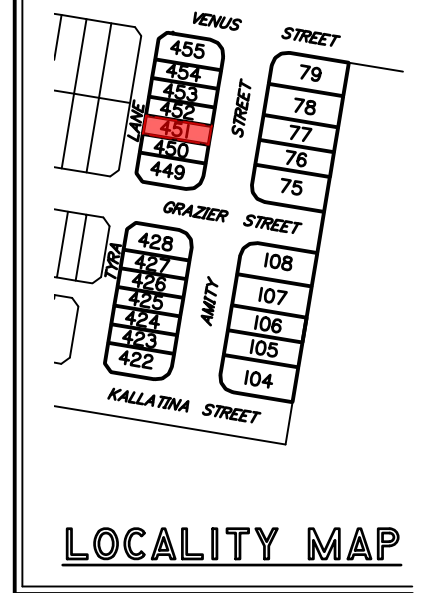
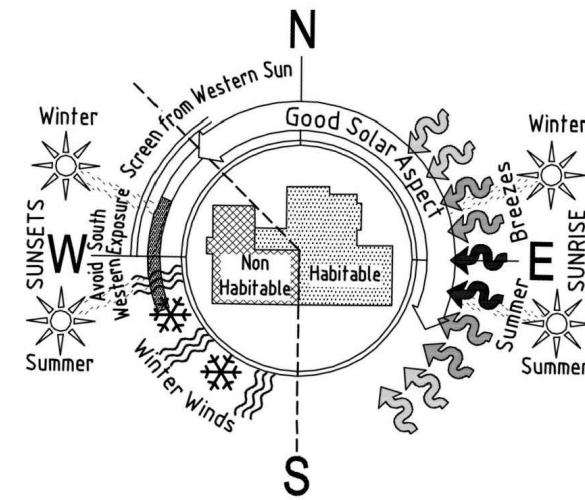

Scale 1:250 – Lengths are in Metres.

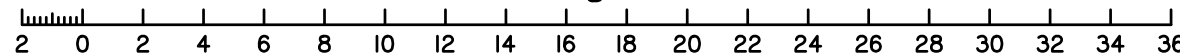

dts urban planning, surveying & development
Brisbane
PO Box 3128, West End QLD 4101
Ph: 07 3118 0600
brisbane@dtsqld.com.au

Mackay
PO Box 11711, Mackay Caneland QLD 4740
Ph: 1300 278 783
mackay@dtsqld.com.au

A	ORIGINAL ISSUE	26/04/22	AA	LM
Issue	Details	Date	Drawn	Checked

HOUSE SITING PLAN
POINTCORP NARANGBA PTY LTD
STAGE 4 "AMITY"
CALLAGHAN ROAD, NARANGBA

Dwg No: A3-6488/451	Issue: A
Project: BNE150725	
File: B150725Hs4.dwg	

HOUSE SITING PLAN PROPOSED LOT 452

Cancelling part of Lot 1007 on SP298953
Locality of Narangba

- These notes form an integral part of this plan. No part of this plan may be reproduced without these notes being included.
- This preliminary house siting plan (PHSP) is intended as an aid in forming an appreciation of the house design potential of the site. It provides a diagrammatic representation of the current Moreton Bay Regional Council Planning Scheme (V4) Dwelling House Code and Queensland Development Code setback requirements applying to the proposed lot. Additional siting requirements may be dictated by the local authority planning scheme or imposed by conditions of the development application approval relating to the creation of the proposed lot. The details shown on this plan are general in nature and are not a comprehensive compilation of standards or conditions to which this proposed lot may be subject. Prospective buyers and builders should seek advice from the approving authority regarding the specific house siting and building restrictions applying to this proposed lot. In addition, service locations indicated on this plan are preliminary only and may differ from the as constructed product.
- The PHSP is not a statutory disclosure.

Contour Interval – 0.25 metre

- 50.0 — Design Contours
- Retaining Wall (Due to plotting limitations the retaining walls shown are not to scale and are indicative only)
- #### Pad Level
- S — Sewer Line/ Manhole
- SW — Stormwater Line / Manhole
- W — Water Line / Fire Hydrant/ Stop Valve
- (SR) — Rising Sewer
- X Water Meter
- Easement Boundary
- Concrete Footpath or Driveway
* Driveways shown are indicative only
- Building Location Envelope
- Built to Boundary Mandatory
- Lower Level (≤ 4.5m Building Height)
- Upper Level (> 4.5m to 7.5m Building Height)
- x-x Garage Limit
- △△ Nominated Garage Location

Meridian: MGA Zone 56 Yes No
Contour Height Datum: AHD

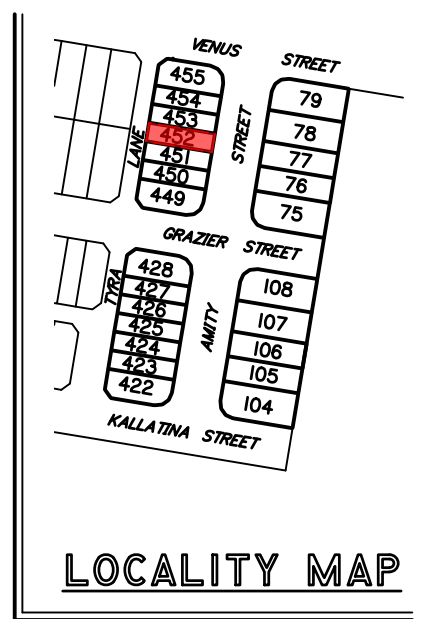
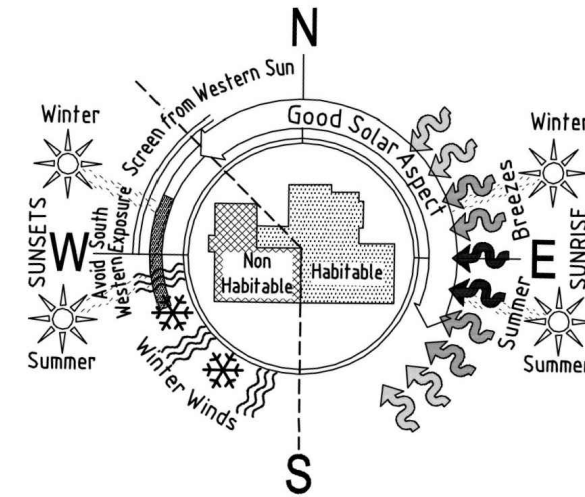

LOCALITY MAP

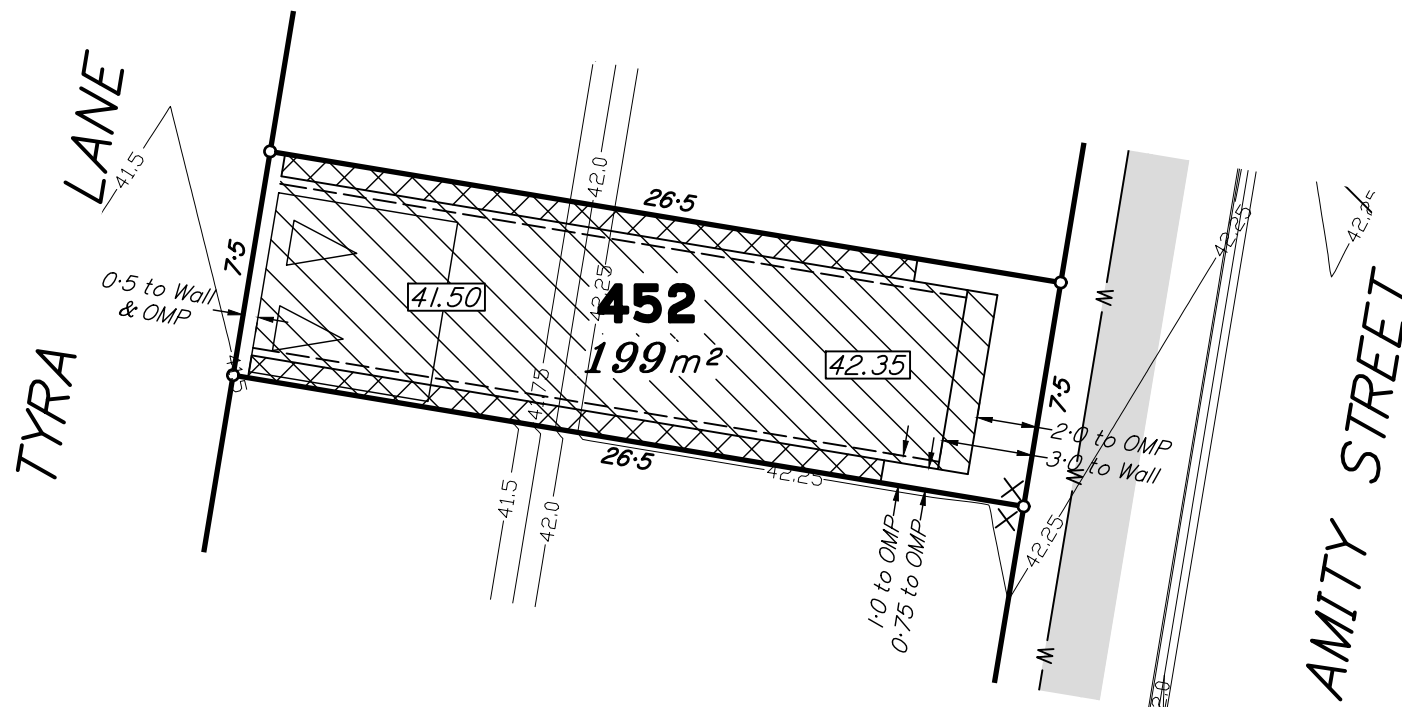

Scale 1:250 – Lengths are in Metres.

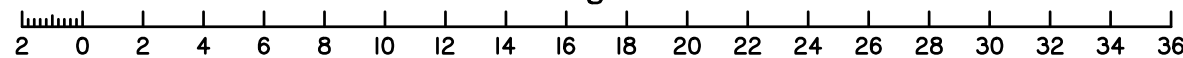

dts urban planning, surveying & development
Brisbane
PO Box 3128, West End QLD 4101
Ph: 07 3118 0600
brisbane@dtsqld.com.au

Mackay
PO Box 11711, Mackay Caneland QLD 4740
Ph: 1300 278 783
mackay@dtsqld.com.au

A	ORIGINAL ISSUE	22/04/22	AA	LM
Issue	Details	Date	Drawn	Checked

HOUSE SITING PLAN
POINTCORP NARANGBA PTY LTD
STAGE 4 "AMITY"
CALLAGHAN ROAD, NARANGBA

Dwg No: A3-6488/452	Issue: A
Project: BNE150725	
File: B150725Hs4.dwg	

HOUSE SITING PLAN PROPOSED LOT 453

Cancelling part of Lot I007 on SP298953
Locality of Narangba

- These notes form an integral part of this plan. No part of this plan may be reproduced without these notes being included.
- This preliminary house siting plan (PHSP) is intended as an aid in forming an appreciation of the house design potential of the site. It provides a diagrammatic representation of the current Moreton Bay Regional Council Planning Scheme (V4) Dwelling House Code and Queensland Development Code setback requirements applying to the proposed lot. Additional siting requirements may be dictated by the local authority planning scheme or imposed by conditions of the development application approval relating to the creation of the proposed lot. The details shown on this plan are general in nature and are not a comprehensive compilation of standards or conditions to which this proposed lot may be subject. Prospective buyers and builders should seek advice from the approving authority regarding the specific house siting and building restrictions applying to this proposed lot. In addition, service locations indicated on this plan are preliminary only and may differ from the as constructed product.
- The PHSP is not a statutory disclosure.

Contour Interval – 0.25 metre

- 50.0 — Design Contours
- Retaining Wall (Due to plotting limitations the retaining walls shown are not to scale and are indicative only)
- #### Pad Level
- S — Sewer Line/ Manhole
- SW — Stormwater Line / Manhole
- W — Water Line / Fire Hydrant/ Stop Valve
- (SR) — Rising Sewer
- X Water Meter
- — Easement Boundary
- Concrete Footpath or Driveway
* Driveways shown are indicative only
- Building Location Envelope
- Built to Boundary Mandatory
- Lower Level (≤ 4.5m Building Height)
- Upper Level (> 4.5m to 7.5m Building Height)
- x-x Garage Limit
- △△ Nominated Garage Location

Meridian: MGA Zone 56 Yes No
Contour Height Datum: AHD

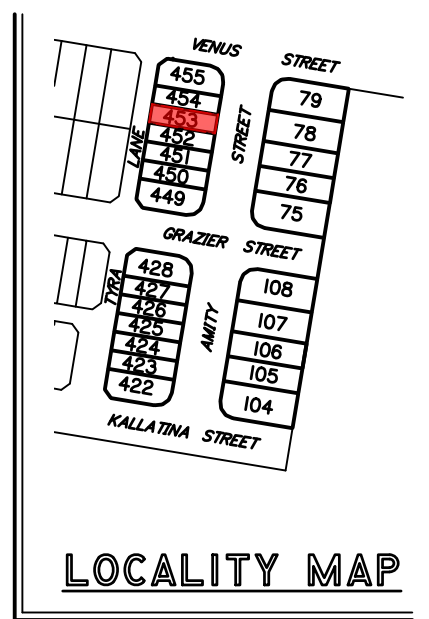
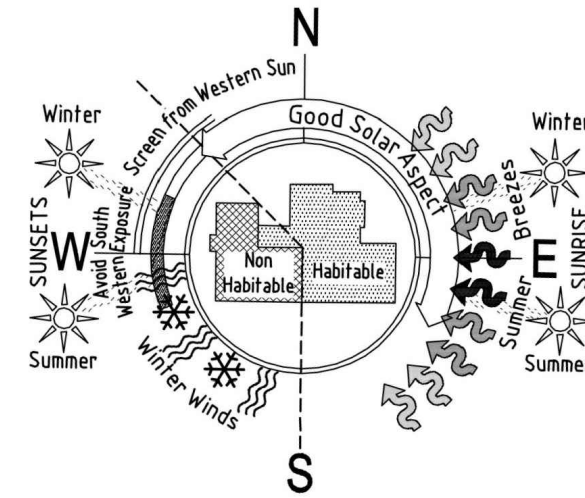

LOCALITY MAP

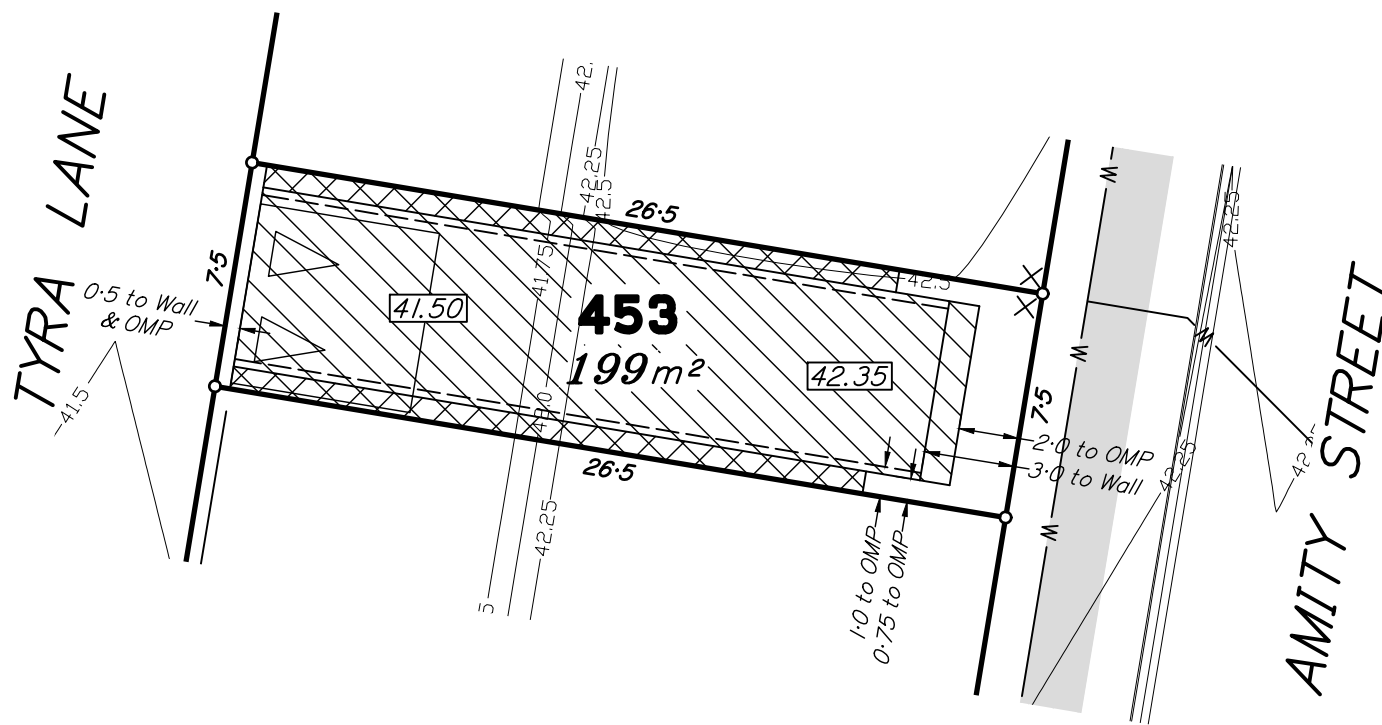

Scale 1:250 – Lengths are in Metres.

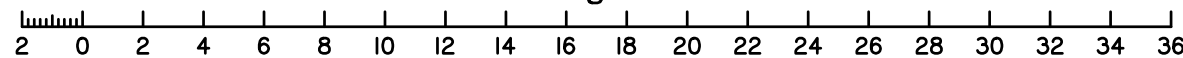

A	ORIGINAL ISSUE	26/04/22	AA	LM
Issue	Details	Date	Drawn	Checked

HOUSE SITING PLAN PROPOSED LOT 454

Cancelling part of Lot 1007 on SP298953
Locality of Narangba

- These notes form an integral part of this plan. No part of this plan may be reproduced without these notes being included.
- This preliminary house siting plan (PHSP) is intended as an aid in forming an appreciation of the house design potential of the site. It provides a diagrammatic representation of the current Moreton Bay Regional Council Planning Scheme (V4) Dwelling House Code and Queensland Development Code setback requirements applying to the proposed lot. Additional siting requirements may be dictated by the local authority planning scheme or imposed by conditions of the development application approval relating to the creation of the proposed lot. The details shown on this plan are general in nature and are not a comprehensive compilation of standards or conditions to which this proposed lot may be subject. Prospective buyers and builders should seek advice from the approving authority regarding the specific house siting and building restrictions applying to this proposed lot. In addition, service locations indicated on this plan are preliminary only and may differ from the as constructed product.
- The PHSP is not a statutory disclosure.

Contour Interval – 0.25 metre

- 50.0 — Design Contours
- Retaining Wall (Due to plotting limitations the retaining walls shown are not to scale and are indicative only)
- #### Pad Level
- S — Sewer Line/ Manhole
- SW — Stormwater Line / Manhole
- w — Water Line / Fire Hydrant/ Stop Valve
- (SR) — Rising Sewer
- X Water Meter
- Easement Boundary
- Concrete Footpath or Driveway
* Driveways shown are indicative only
- Building Location Envelope
- Built to Boundary Mandatory
- Lower Level (≤ 4.5m Building Height)
- Upper Level (> 4.5m to 7.5m Building Height)
- x-x Garage Limit
- △△ Nominated Garage Location

Meridian: MGA Zone 56 Yes No
Contour Height Datum: AHD

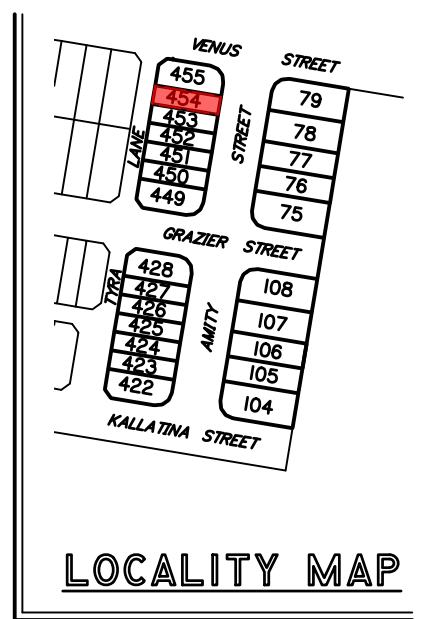
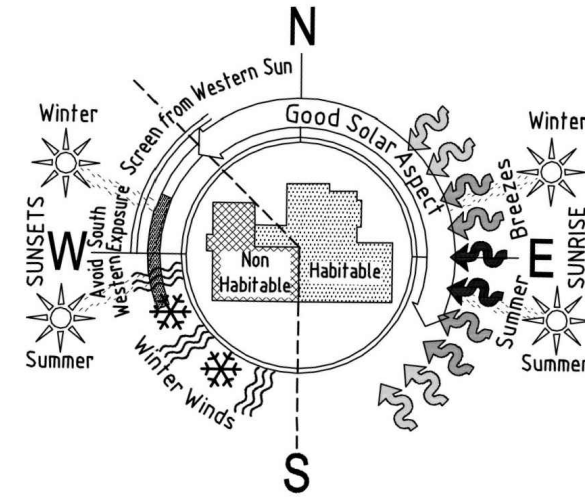

LOCALITY MAP

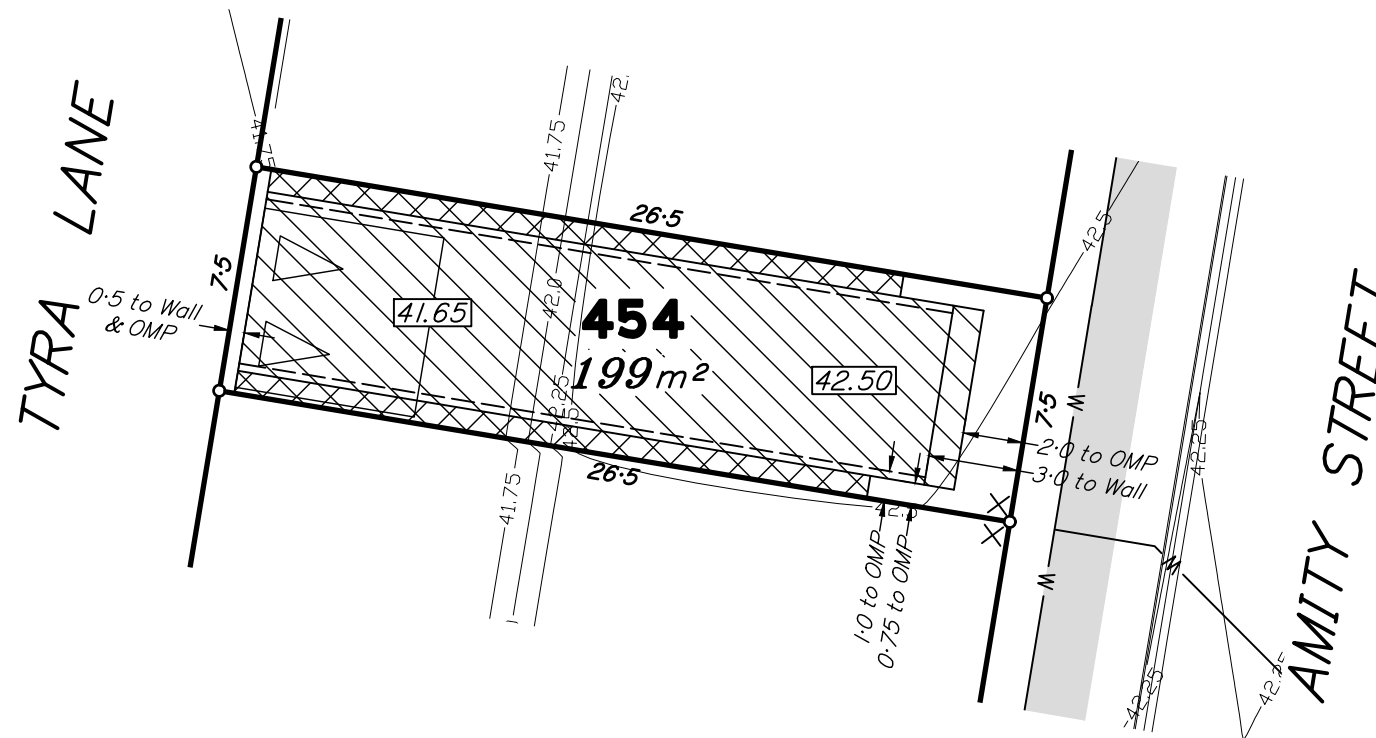

Scale 1:250 – Lengths are in Metres.

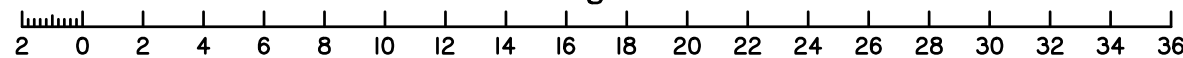

dts urban planning, surveying & development
Brisbane
PO Box 3128, West End QLD 4101
Ph: 07 3118 0600
brisbane@dtsqld.com.au

Mackay
PO Box 11711, Mackay Caneland QLD 4740
Ph: 1300 278 783
mackay@dtsqld.com.au

A	ORIGINAL ISSUE	22/04/22	AA	LM
Issue	Details	Date	Drawn	Checked

HOUSE SITING PLAN
POINTCORP NARANGBA PTY LTD
STAGE 4 "AMITY"
CALLAGHAN ROAD, NARANGBA

Dwg No: A3-6488/454	Issue: A
Project: BNE150725	
File: B150725Hs4.dwg	

