

HOUSE SITING PLAN PROPOSED LOT 75

Cancelling part of Lot 1007 on SP298953
Locality of Narangba

- These notes form an integral part of this plan. No part of this plan may be reproduced without these notes being included.
- This preliminary house siting plan (PHSP) is intended as an aid in forming an appreciation of the house design potential of the site. It provides a diagrammatic representation of the current Moreton Bay Regional Council Planning Scheme (V4) Dwelling House Code and Queensland Development Code setback requirements applying to the proposed lot. Additional siting requirements may be dictated by the local authority planning scheme or imposed by conditions of the development application approval relating to the creation of the proposed lot. The details shown on this plan are general in nature and are not a comprehensive compilation of standards or conditions to which this proposed lot may be subject. Prospective buyers and builders should seek advice from the approving authority regarding the specific house siting and building restrictions applying to this proposed lot. In addition, service locations indicated on this plan are preliminary only and may differ from the as constructed product.
- The PHSP is not a statutory disclosure.

Contour Interval – 0.25 metre

- 50.0 — Design Contours
- Retaining Wall (Due to plotting limitations the retaining walls shown are not to scale and are indicative only)
- ###.### Pad Level
- S Sewer Line / Manhole
- SW Stormwater Line / Manhole
- W Water Line / Fire Hydrant / Stop Valve
- (SR) Rising Sewer
- X Water Meter
- Easement Boundary
- Concrete Footpath or Driveway
* Driveways shown are indicative only
- Building Location Envelope
- Built to Boundary Mandatory
- Lower Level ($\leq 4.5\text{m}$ Building Height)
- Upper Level ($> 4.5\text{m}$ to 7.5m Building Height)
- x-x Garage Limit

Meridian: MGA Zone 56 Yes No
Contour Height Datum: AHD

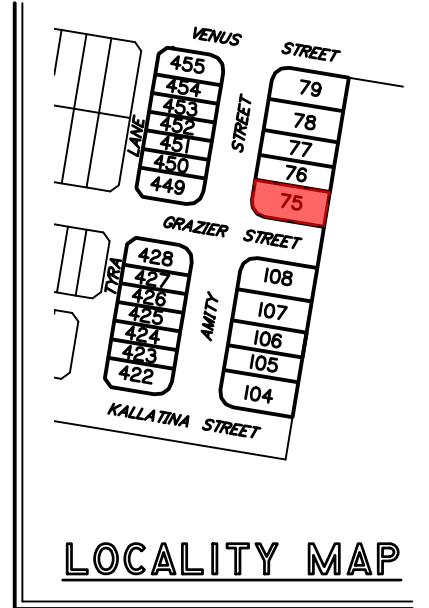
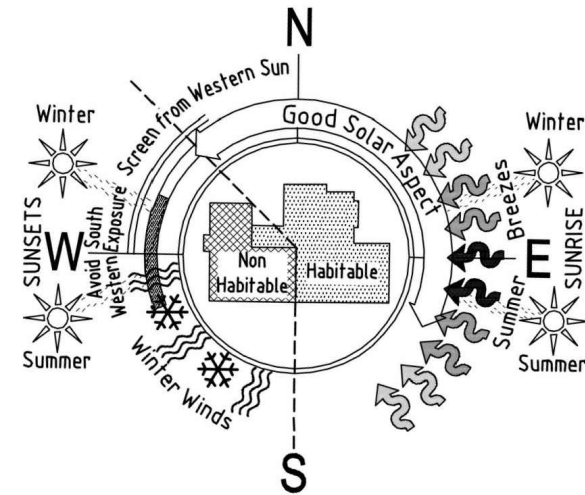

LOCALITY MAP

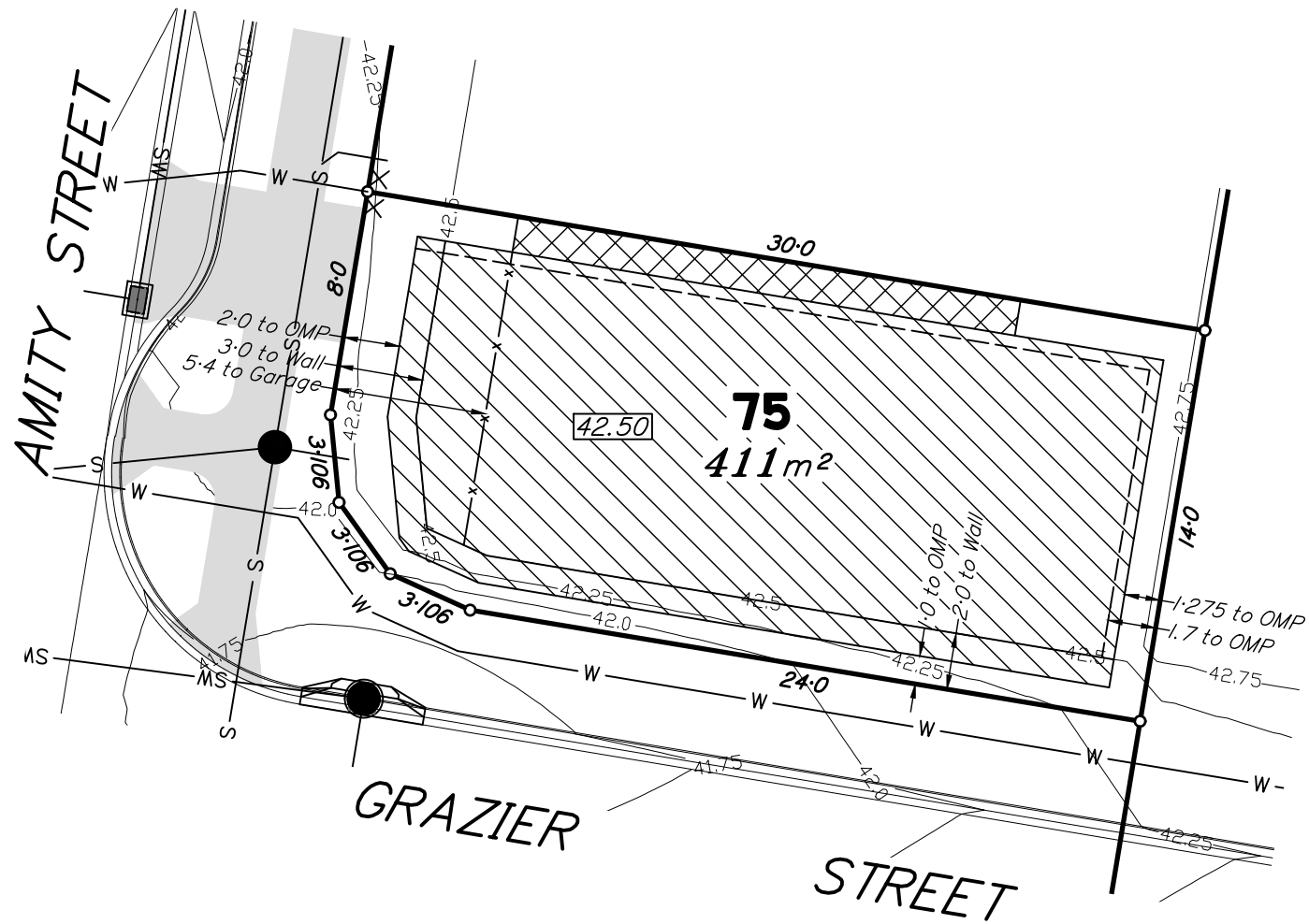

Scale 1:250 – Lengths are in Metres.

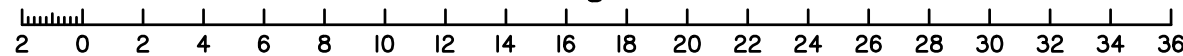

dts urban planning, surveying & development
Brisbane MacKay
PO Box 3128, West End QLD 4101 PO Box 11711, Mackay Caneland QLD 4740
Ph: 07 3118 0600 Ph: 1300 278 783
brisbane@dtsqld.com.au mackay@dtsqld.com.au

B	UPDATE DIMENSION DESCRIPTIONS	26/04/22	AA	AV
A	ORIGINAL ISSUE	14/04/22	AA	AV
Issue	Details	Date	Drawn	Checked

HOUSE SITING PLAN
POINTCORP NARANGBA PTY LTD
STAGE 4 "AMITY"
CALLAGHAN ROAD, NARANGBA

Dwg No: A3-6488/75	Issue: B
Project: BNE150725	
File: B150725Hs4.dwg	

HOUSE SITING PLAN PROPOSED LOT 76

Cancelling part of Lot 1007 on SP298953
Locality of Narangba

- These notes form an integral part of this plan. No part of this plan may be reproduced without these notes being included.
- This preliminary house siting plan (PHSP) is intended as an aid in forming an appreciation of the house design potential of the site. It provides a diagrammatic representation of the current Moreton Bay Regional Council Planning Scheme (V4) Dwelling House Code and Queensland Development Code setback requirements applying to the proposed lot. Additional siting requirements may be dictated by the local authority planning scheme or imposed by conditions of the development application approval relating to the creation of the proposed lot. The details shown on this plan are general in nature and are not a comprehensive compilation of standards or conditions to which this proposed lot may be subject. Prospective buyers and builders should seek advice from the approving authority regarding the specific house siting and building restrictions applying to this proposed lot. In addition, service locations indicated on this plan are preliminary only and may differ from the as constructed product.
- The PHSP is not a statutory disclosure.

Contour Interval – 0.25 metre

- 50.0 — Design Contours
- Retaining Wall (Due to plotting limitations the retaining walls shown are not to scale and are indicative only)
- #### Pad Level
- S Sewer Line / Manhole
- SW Stormwater Line / Manhole
- w Water Line / Fire Hydrant / Stop Valve
- (SR) Rising Sewer
- x Water Meter
- Easement Boundary
- Concrete Footpath or Driveway
* Driveways shown are indicative only
- Building Location Envelope
- Built to Boundary Mandatory
- Lower Level (≤ 4.5m Building Height)
- Upper Level (> 4.5m to 7.5m Building Height)
- x-x Garage Limit

Meridian: MGA Zone 56 Yes No
Contour Height Datum: AHD

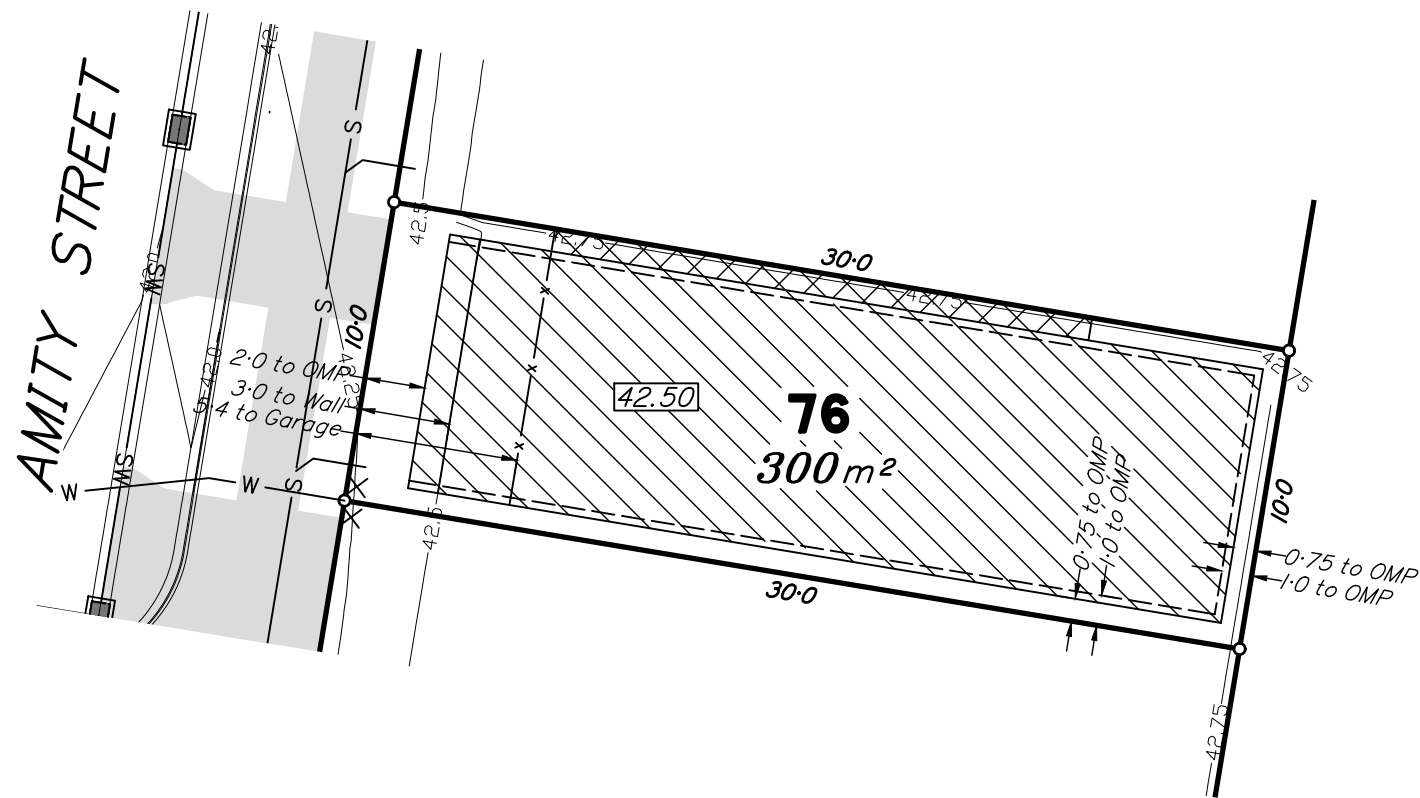
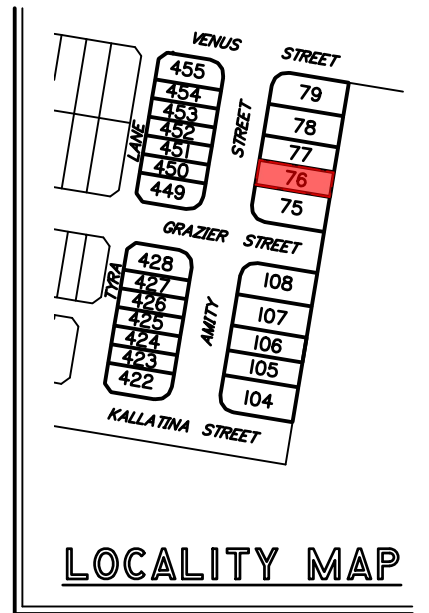
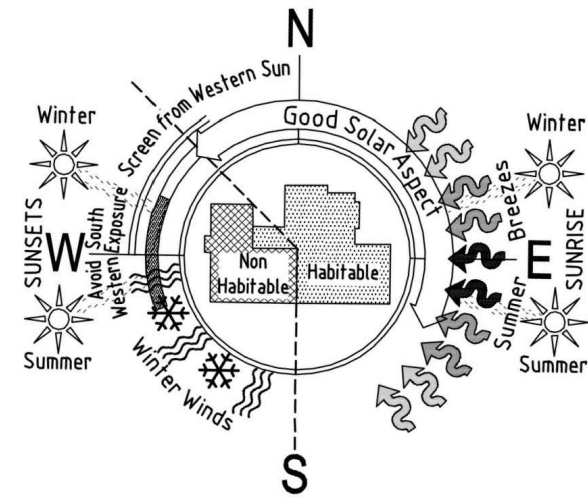

Scale 1:250 – Lengths are in Metres.

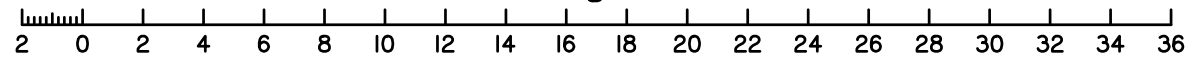

dts urban planning, surveying & development
Brisbane MacKay
PO Box 3128, West End QLD 4101 PO Box 11711, Mackay Caneland QLD 4740
Ph: 07 3118 0600 Ph: 1300 278 783
brisbane@dtsqld.com.au mackay@dtsqld.com.au

B	UPDATE DIMENSION DESCRIPTIONS	26/04/22	AA	AV
A	ORIGINAL ISSUE	14/04/22	AA	AV
Issue	Details	Date	Drawn	Checked

HOUSE SITING PLAN
POINTCORP NARANGBA PTY LTD
STAGE 4 "AMITY"
CALLAGHAN ROAD, NARANGBA

Dwg No: A3-6488/76	Issue: B
Project: BNE150725	
File: B150725Hs4.dwg	

HOUSE SITING PLAN PROPOSED LOT 77

Cancelling part of Lot 1007 on SP298953
Locality of Narangba

- These notes form an integral part of this plan. No part of this plan may be reproduced without these notes being included.
- This preliminary house siting plan (PHSP) is intended as an aid in forming an appreciation of the house design potential of the site. It provides a diagrammatic representation of the current Moreton Bay Regional Council Planning Scheme (V4) Dwelling House Code and Queensland Development Code setback requirements applying to the proposed lot. Additional siting requirements may be dictated by the local authority planning scheme or imposed by conditions of the development application approval relating to the creation of the proposed lot. The details shown on this plan are general in nature and are not a comprehensive compilation of standards or conditions to which this proposed lot may be subject. Prospective buyers and builders should seek advice from the approving authority regarding the specific house siting and building restrictions applying to this proposed lot. In addition, service locations indicated on this plan are preliminary only and may differ from the as constructed product.
- The PHSP is not a statutory disclosure.

Contour Interval – 0.25 metre

- 50.0 — Design Contours
- Retaining Wall (Due to plotting limitations the retaining walls shown are not to scale and are indicative only)
- ### Pad Level
- S Sewer Line / Manhole
- SW Stormwater Line / Manhole
- w Water Line / Fire Hydrant / Stop Valve
- (SR) Rising Sewer
- x Water Meter
- Easement Boundary
- Concrete Footpath or Driveway
* Driveways shown are indicative only
- Building Location Envelope
- Built to Boundary Mandatory
- Lower Level (≤ 4.5m Building Height)
- Upper Level (> 4.5m to 7.5m Building Height)
- x Garage Limit

Meridian: MGA Zone 56 Yes No
Contour Height Datum: AHD

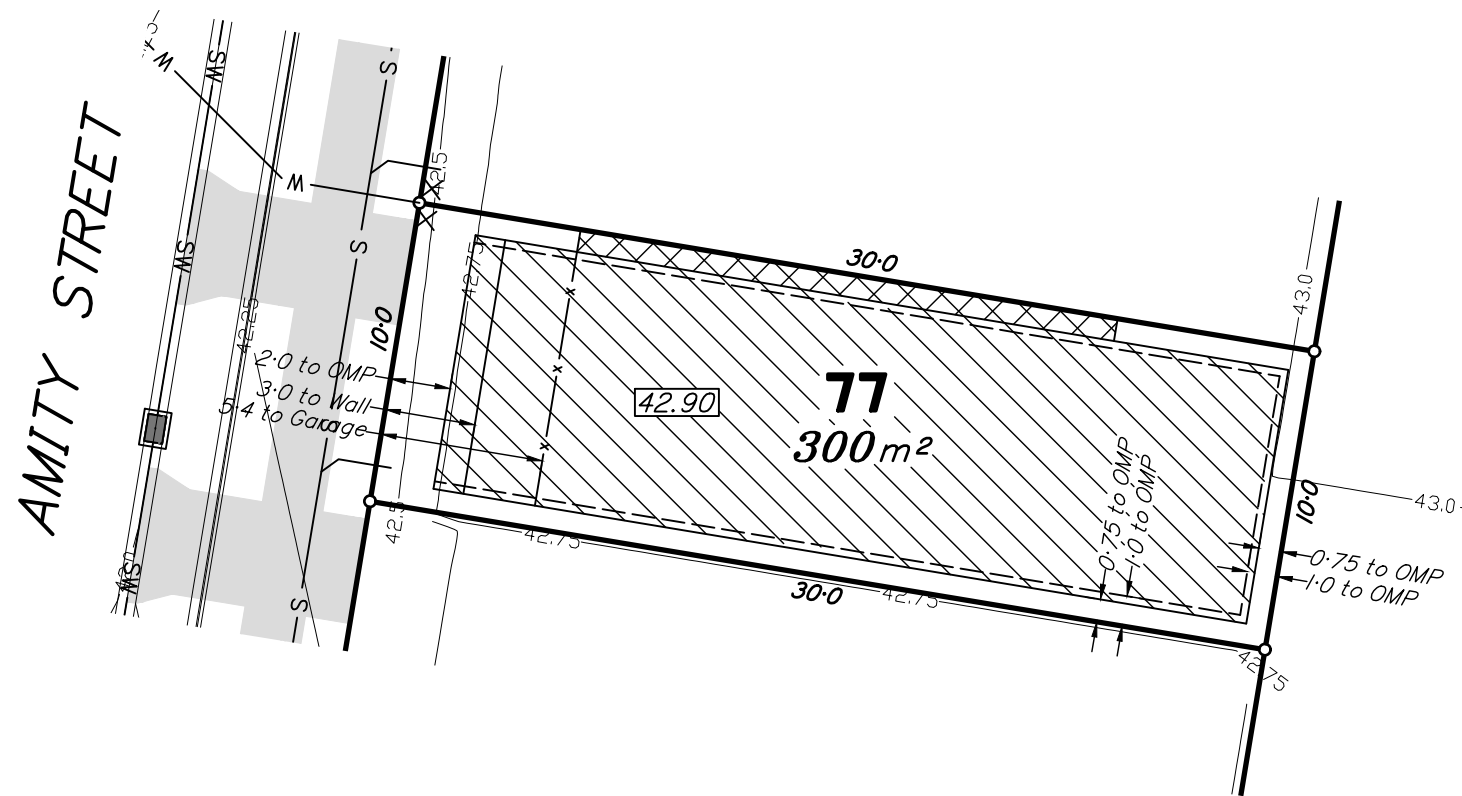
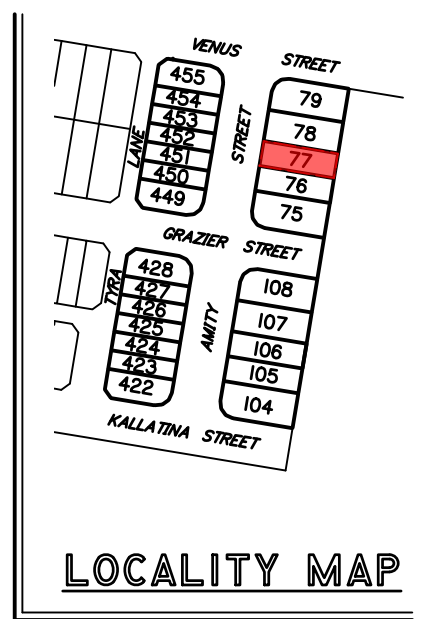
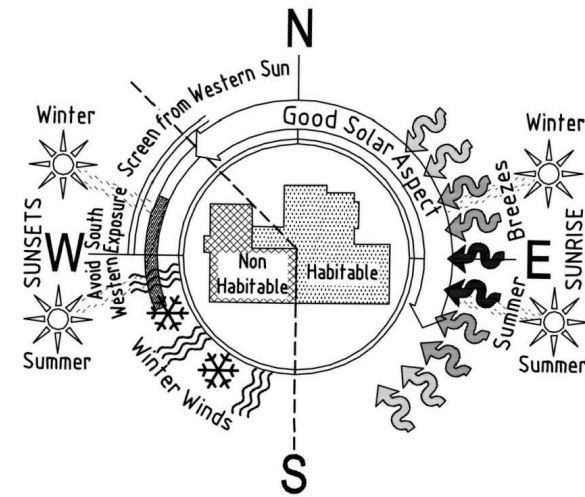

Scale 1:250 – Lengths are in Metres.

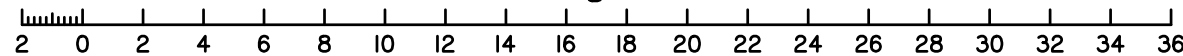

dts urban planning, surveying & development
Brisbane Macquay
PO Box 3128, West End QLD 4101 PO Box 11711, Mackay Caneland QLD 4740
Ph: 07 3118 0600 Ph: 1300 278 783
brisbane@dtsqld.com.au mackay@dtsqld.com.au

B	UPDATE DIMENSION DESCRIPTIONS	26/04/22	AA	AV
A	ORIGINAL ISSUE	14/04/22	AA	AV
Issue	Details	Date	Drawn	Checked

HOUSE SITING PLAN
POINTCORP NARANGBA PTY LTD
STAGE 4 "AMITY"
CALLAGHAN ROAD, NARANGBA

Dwg No: A3-6488/77	Issue: B
Project: BNE150725	
File: B150725Hs4.dwg	

HOUSE SITING PLAN PROPOSED LOT 78

Cancelling part of Lot 1007 on SP298953
Locality of Narangba

- These notes form an integral part of this plan. No part of this plan may be reproduced without these notes being included.
- This preliminary house siting plan (PHSP) is intended as an aid in forming an appreciation of the house design potential of the site. It provides a diagrammatic representation of the current Moreton Bay Regional Council Planning Scheme (V4) Dwelling House Code and Queensland Development Code setback requirements applying to the proposed lot. Additional siting requirements may be dictated by the local authority planning scheme or imposed by conditions of the development application approval relating to the creation of the proposed lot. The details shown on this plan are general in nature and are not a comprehensive compilation of standards or conditions to which this proposed lot may be subject. Prospective buyers and builders should seek advice from the approving authority regarding the specific house siting and building restrictions applying to this proposed lot. In addition, service locations indicated on this plan are preliminary only and may differ from the as constructed product.
- The PHSP is not a statutory disclosure.

Contour Interval – 0.25 metre

- 50.0 — Design Contours
- Retaining Wall (Due to plotting limitations the retaining walls shown are not to scale and are indicative only)
- ### Pad Level
- S Sewer Line / Manhole
- SW Stormwater Line / Manhole
- w Water Line / Fire Hydrant / Stop Valve
- (SR) Rising Sewer
- x Water Meter
- Easement Boundary
- Concrete Footpath or Driveway
* Driveways shown are indicative only
- Building Location Envelope
- Built to Boundary Mandatory
- Lower Level (≤ 4.5m Building Height)
- Upper Level (> 4.5m to 7.5m Building Height)
- x-x Garage Limit

Meridian: MGA Zone 56 Yes No
Contour Height Datum: AHD

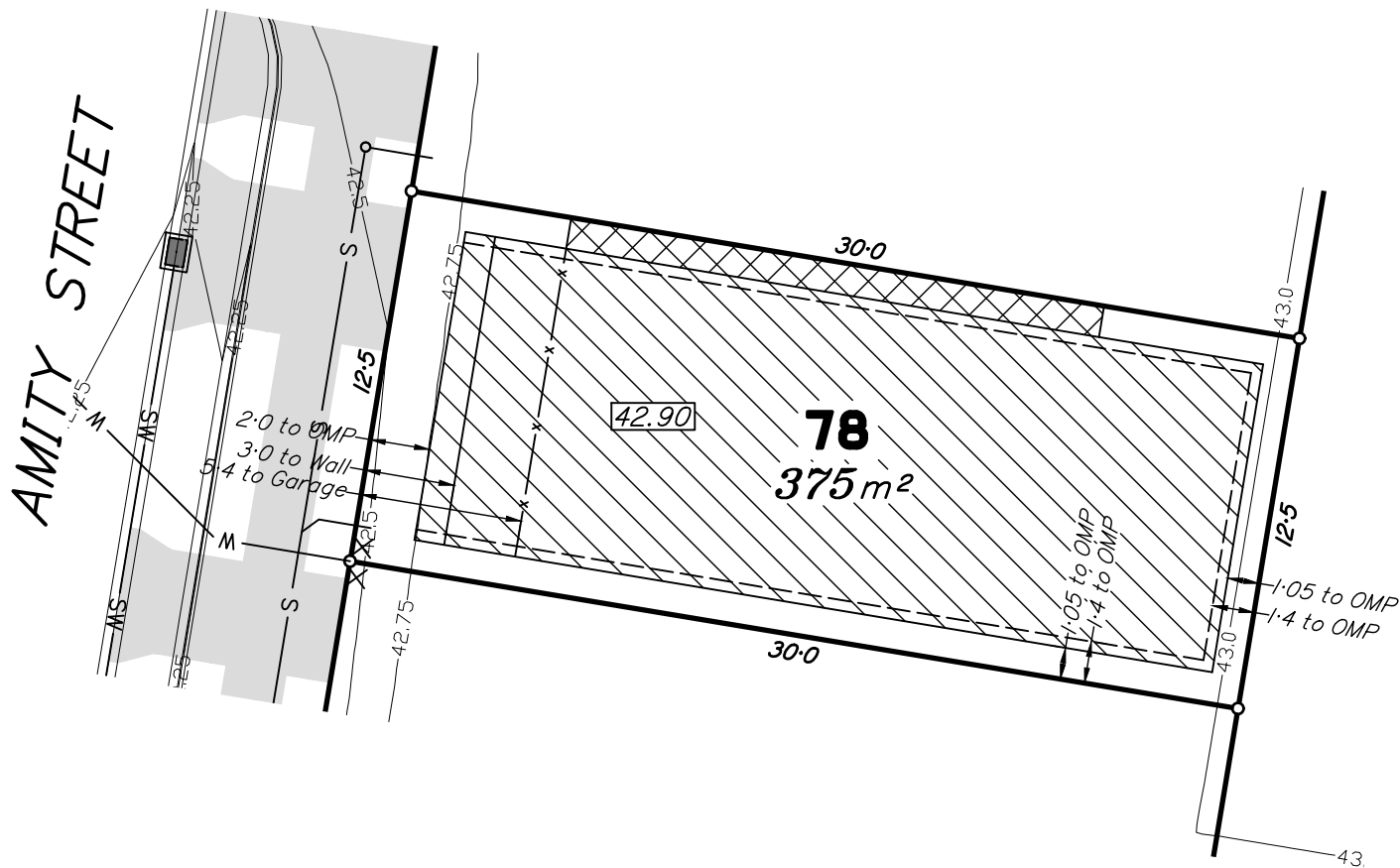
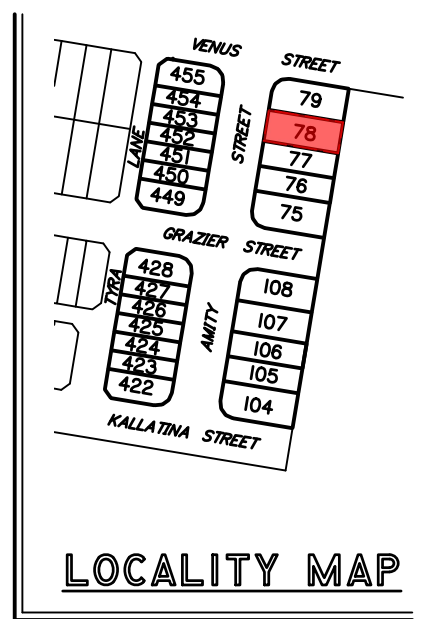
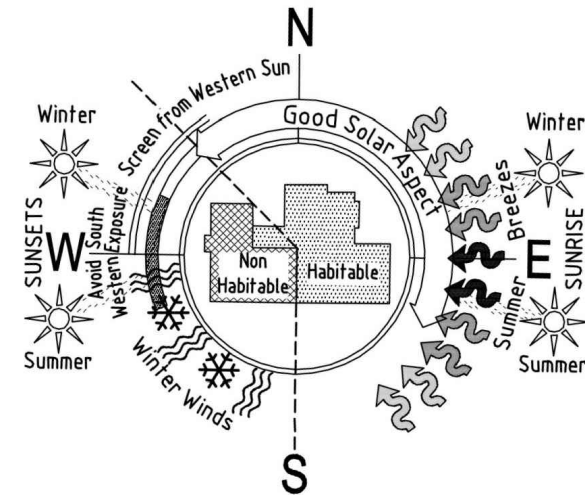

Scale 1:250 – Lengths are in Metres.

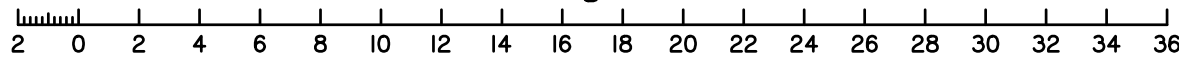

dts urban planning, surveying & development
Brisbane Macquay
PO Box 3128, West End QLD 4101 PO Box 11711, Mackay Caneland QLD 4740
Ph: 07 3118 0600 Ph: 1300 278 783
brisbane@dtsqld.com.au mackay@dtsqld.com.au

B	UPDATE DIMENSION DESCRIPTIONS	26/04/22	AA	AV
A	ORIGINAL ISSUE	14/04/22	AA	AV
Issue	Details	Date	Drawn	Checked

HOUSE SITING PLAN
POINTCORP NARANGBA PTY LTD
STAGE 4 "AMITY"
CALLAGHAN ROAD, NARANGBA

Dwg No: A3-6488/78	Issue: B
Project: BNE150725	
File: B150725Hs4.dwg	

HOUSE SITING PLAN PROPOSED LOT 79

Cancelling part of Lot I007 on SP298953
Locality of Narangba

- These notes form an integral part of this plan. No part of this plan may be reproduced without these notes being included.
- This preliminary house siting plan (PHSP) is intended as an aid in forming an appreciation of the house design potential of the site. It provides a diagrammatic representation of the current Moreton Bay Regional Council Planning Scheme (V4) Dwelling House Code and Queensland Development Code setback requirements applying to the proposed lot. Additional siting requirements may be dictated by the local authority planning scheme or imposed by conditions of the development application approval relating to the creation of the proposed lot. The details shown on this plan are general in nature and are not a comprehensive compilation of standards or conditions to which this proposed lot may be subject. Prospective buyers and builders should seek advice from the approving authority regarding the specific house siting and building restrictions applying to this proposed lot. In addition, service locations indicated on this plan are preliminary only and may differ from the as constructed product.
- The PHSP is not a statutory disclosure.

Contour Interval - 0.25 metre

- 50.0 Design Contours
- Retaining Wall (Due to plotting limitations the retaining walls shown are not to scale and are indicative only)
- Pad Level
- S Sewer Line / Manhole
- SW Stormwater Line / Manhole
- w Water Line / Fire Hydrant / Stop Valve
- (SR) Rising Sewer
- Water Meter
- Easement Boundary
- Concrete Footpath or Driveway
* Driveways shown are indicative only
- Building Location Envelope
- Built to Boundary Mandatory
- Lower Level ($\leq 4.5\text{m}$ Building Height)
- Upper Level ($> 4.5\text{m}$ to 7.5m Building Height)
- Garage Limit

Meridian: MGA Zone 56 Yes No
Contour Height Datum: AHD

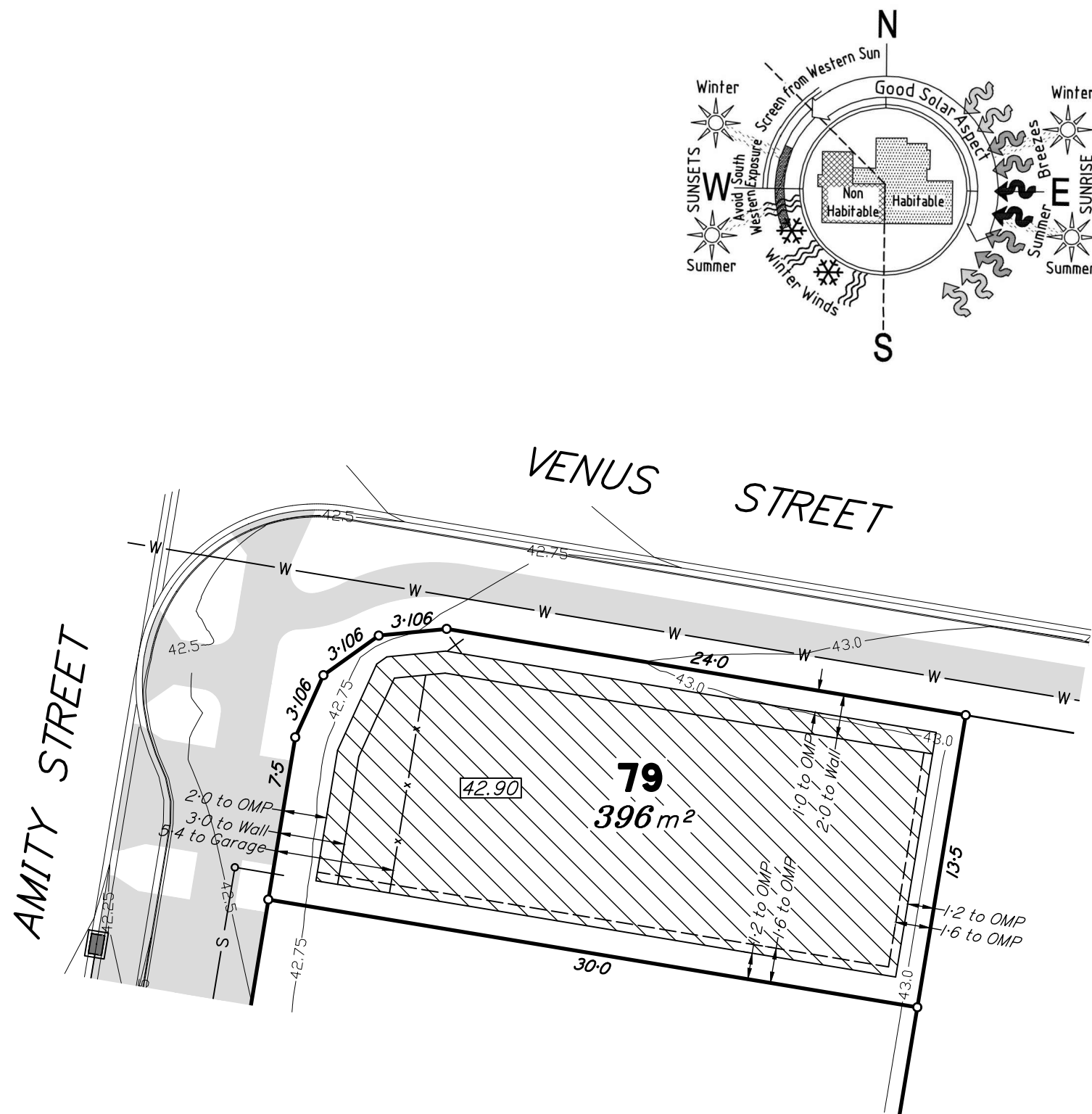

Scale 1:250 - Lengths are in Metres.

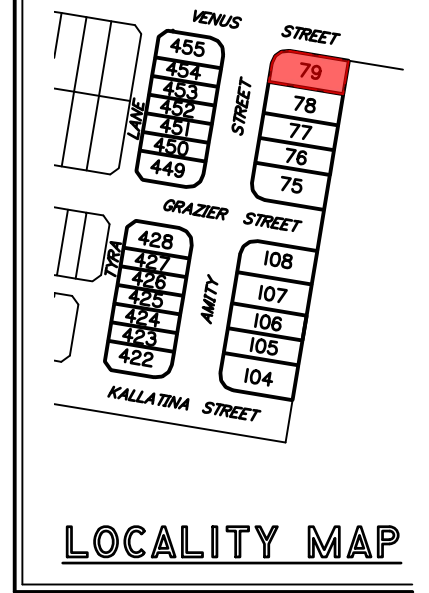
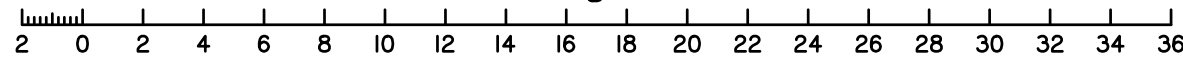

LOCALITY MAP

dts urban planning, surveying & development
Brisbane MacKay
PO Box 3128, West End QLD 4101 PO Box 11711, Mackay Caneland QLD 4740
Ph: 07 3118 0600 Ph: 1300 278 783
brisbane@dtsqld.com.au mackay@dtsqld.com.au

B	UPDATE DIMENSION DESCRIPTIONS ORIGINAL ISSUE	26/04/22	AA	AV
A		14/04/22	AA	AV
Issue	Details	Date	Drawn	Checked

HOUSE SITING PLAN
POINTCORP NARANGBA PTY LTD
STAGE 4 "AMITY"
CALLAGHAN ROAD, NARANGBA

Dwg No: A3-6488/79	Issue: B
Project: BNE150725	
File: B150725Hs4.dwg	